

# Logosol Intelligent Stepper Drive LS-143

Doc. # 712143001 / Rev. 1.6, 10/02/2000

## Features

- ❑ Position and velocity mode
- ❑ 32-bit position counter
- ❑ Trapezoidal profile generator
- ❑ Up to 50KHz step rate
- ❑ Full and half step modes
- ❑ Member of Logosol's distributed motion control network
- ❑ High output current - 3A
- ❑ Single power supply - 12 to 40V
- ❑ 20 kHz chopping rate
- ❑ Comprehensive motor output short-circuit protection:
  - Output to output
  - Output to ground
  - Output to power
- ❑ Programmable auto-switching running and holding currents
- ❑ Digital inputs
  - Positive limit
  - Negative limit
  - Stop
  - Home
- ❑ Analog input - 0.5 to 30 V full scale
- ❑ Communication speed 19.2 - 115.2 Kbps
- ❑ Command rate up to 1000/sec
- ❑ Small footprint (5" x 3.4" x 1.55")



## Description

LS-143 is a single-axis intelligent controller with integrated amplifier designed for applications using two-phase stepper motors.

The drive is a member of Logosol's distributed motion control network. Up to 31 intelligent stepper drives can be controlled over a multi-drop full duplex RS-485 network. Standard RJ-45 connectors and commercially available cables are used to connect modules into a network.

LS-143 is equipped with various safety features such as short circuit protection for the motor and amplifier, over travel limit switch inputs, stop and home inputs. The motor current can be programmed in the range of 0.6A to 3A using commands from the host computer.

# Logosol Intelligent Stepper Drive LS-143

Doc. # 712143001 / Rev. 1.6, 10/02/2000

## **TECHNICAL SPECIFICATIONS** rated at 25°C ambient, POWER (+) = 24VDC

POWER SUPPLY VOLTAGE	12 to 40 V DC, 42V absolute maximum
MAX MOTOR OUTPUT CURRENT Running Holding	3A (per phase) 2.5A (per phase)
PWM SWITCHING FREQUENCY	20KHz
STEP FREQUENCY	9.536Hz ÷ 50KHz
SERIAL BAUD RATE	19.2 – 115.2 Kbps
INPUTS Digital Inputs Analog input	0 ≤ LOW ≤ 1.0V, 2.8V ≤ HIGH ≤ 48V 0.5 to 30 V full scale adjustment. 10 KOhm input resistance
LED Two intensity levels	Power 'ok' – low intensity Enabled – high intensity
+5V SOURCE Max current	200 mA for all pins combined
PROTECTION Short circuit	Motor output to motor output Motor output to GND Motor output to POWER (+)
THERMAL REQUIREMENTS Storage temperature range Operating temperature range	–30 to +85 °C 0 to 45 °C
MECHANICAL Size Weight	L=5", H=3.40", D=1.55" 0.55lb. (250gr.)
MATING CONNECTORS Power & Motor Digital Inputs Analog Input Communication	Magnum EM2565-07-VL or Phoenix MSTB 2.5/7-ST-5.08 Molex 22-01-3127 housing with 08-50-0114 pins (12 pcs.) Molex 22-01-3037 housing with 08-50-0114 pins (3 pcs.) 8 pin RJ-45

# Logosol Intelligent Stepper Drive LS-143

Doc. # 712143001 / Rev. 1.6, 10/02/2000

## DIMENSIONAL DRAWING

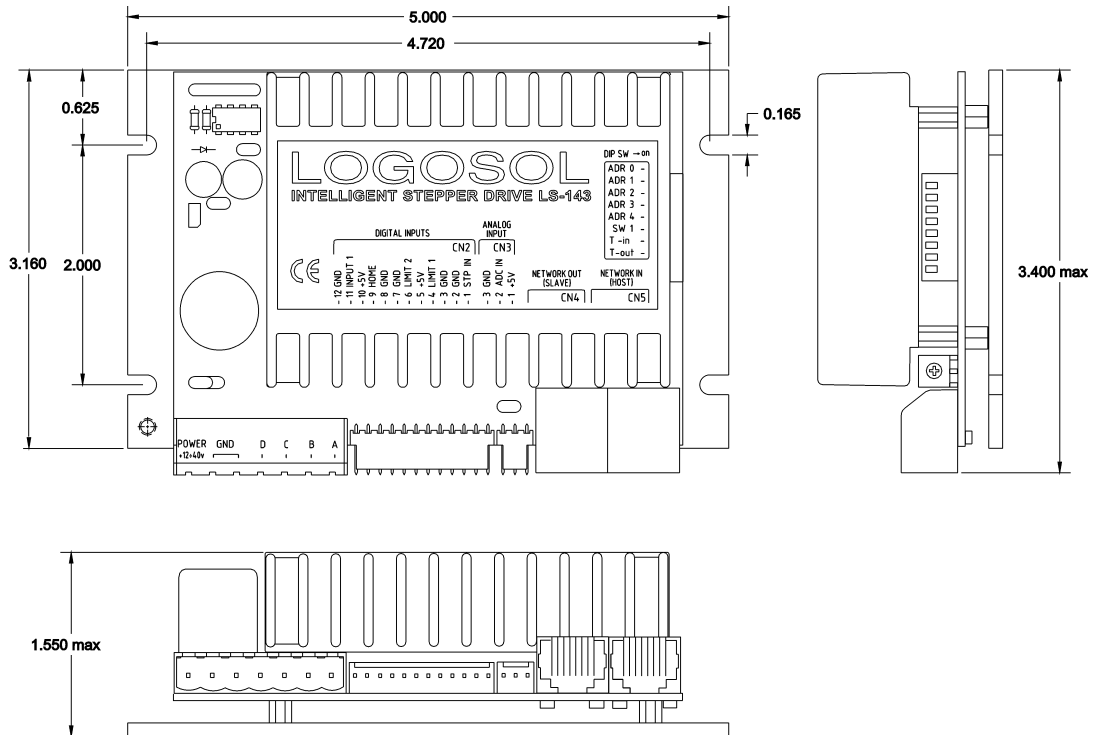

## CONNECTORS AND CONTROLS LAYOUT

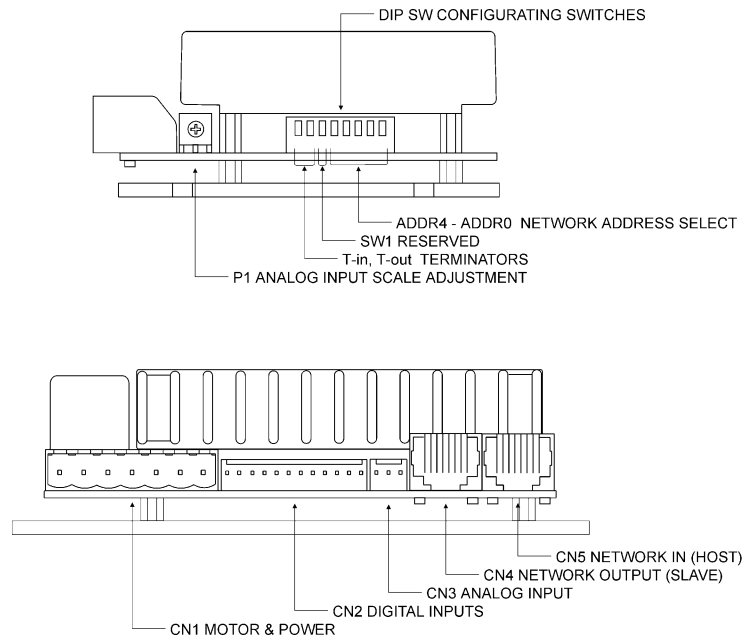

## ORDERING GUIDE

PART NUMBER	MODEL	DESCRIPTION
912143001	LS-143	Intelligent Stepper Drive
230601010	LS-143-CN	Mating connector kit

# Logosol Intelligent Stepper Drive LS-143

Doc. # 712143001 / Rev. 1.6, 10/02/2000

## CONNECTORS AND PINOUT

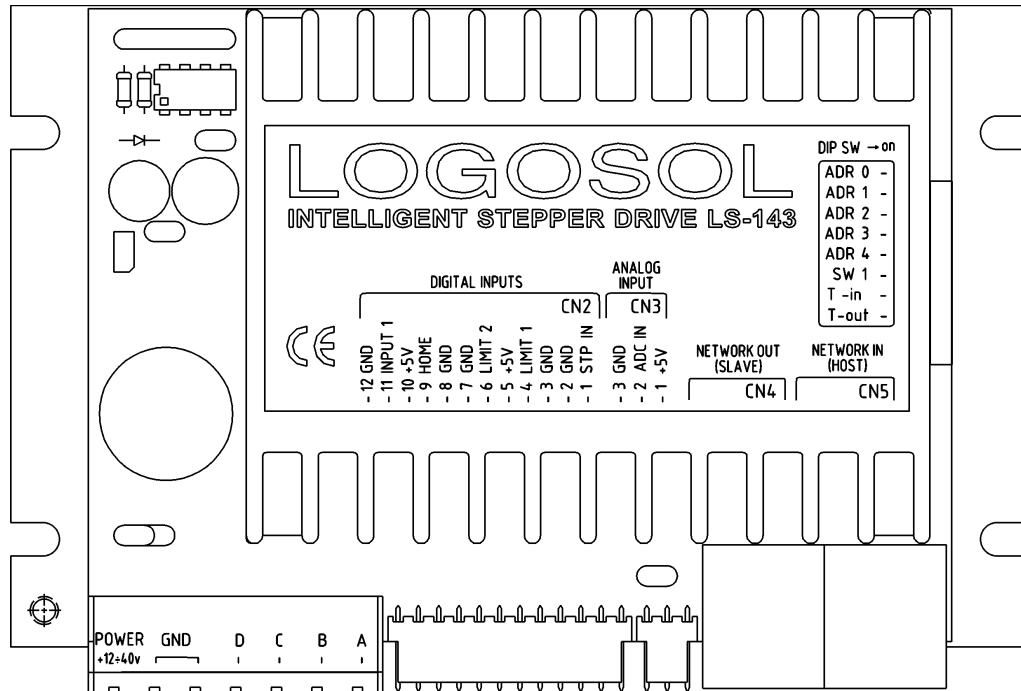

### DIP SW – DIP SWITCH

SW	SIGNAL	DESCRIPTION
1	T-out	Transmit line terminator
2	T-in	Receive line terminator
3	SW1	Reserved (must be OFF)
4	ADR 4	Network address select (MSB)
5	ADR 3	Network address select
6	ADR 2	Network address select
7	ADR 1	Network address select
8	ADR 0	Network address select (LSB)

### CN1 – POWER AND MOTOR CONNECTOR

PIN	SIGNAL	DESCRIPTION
1	POWER (+)	12 – 40V power supply, positive terminal
2	GND*	Power supply ground
3	GND*	Power supply ground
4	D	Output to motor terminal D (winding CD)
5	C	Output to motor terminal C (winding CD)
6	B	Output to motor terminal B (winding AB)
7	A	Output to motor terminal A (winding AB)

# Logosol Intelligent Stepper Drive LS-143

Doc. # 712143001 / Rev. 1.6, 10/02/2000

## CN2 – DIGITAL INPUTS

PIN	SIGNAL	DESCRIPTION
1	STP IN	Stop input HIGH (open) = Motor Stop LOW (short to GND) = Motor Enabled
2	GND*	Signal ground
3	GND*	Signal ground
4	LIMIT 1	Positive limit input HIGH (open) = Positive Direction Disabled LOW (short to GND) = Positive Direction Enabled
5	+5V**	+5V Power supply
6	LIMIT 2	Negative limit input HIGH (open) = Negative Direction Disabled LOW (short to GND) = Negative Direction Enabled
7	GND*	Signal ground
8	GND*	Signal ground
9	HOME	Home input
10	+5V**	+5V Power supply
11	INPUT 1	General purpose input
12	GND*	Signal ground

## CN3 – ANALOG INPUT

PIN	SIGNAL	DESCRIPTION
1	+5V**	+5V Power supply
2	ADC IN	Analog input
3	GND*	Signal ground

## CN4 – NETWORK OUT (SLAVE)

PIN	SIGNAL	DESCRIPTION
1	N.C.	Not connected
2	GND*	Interface ground
3	+TX	(+) Transmit data
4	-TX	(-) Transmit data
5	-RX	(-) Receive data
6	+RX	(+) Receive data
7	-A out	(-) Address output
8	+A out	(+) Address output

## CN5 – NETWORK IN (HOST)

PIN	SIGNAL	DESCRIPTION
1	+5V**	RS-232 adapter power supply
2	GND*	Interface ground
3	+TX	(+) Transmit data
4	-TX	(-) Transmit data
5	-RX	(-) Receive data
6	+RX	(+) Receive data
7	-A in	(-) Address input
8	+A in	(+) Address input

\* POWER GND and GND are electrically connected. Drive's case is isolated from the drive's circuitry and may be grounded externally.

\*\* 200 mA Max current for all four pins combined.

# Logosol Intelligent Stepper Drive LS-143

Doc. # 712143001 / Rev. 1.6, 10/02/2000

## SAMPLE APPLICATION

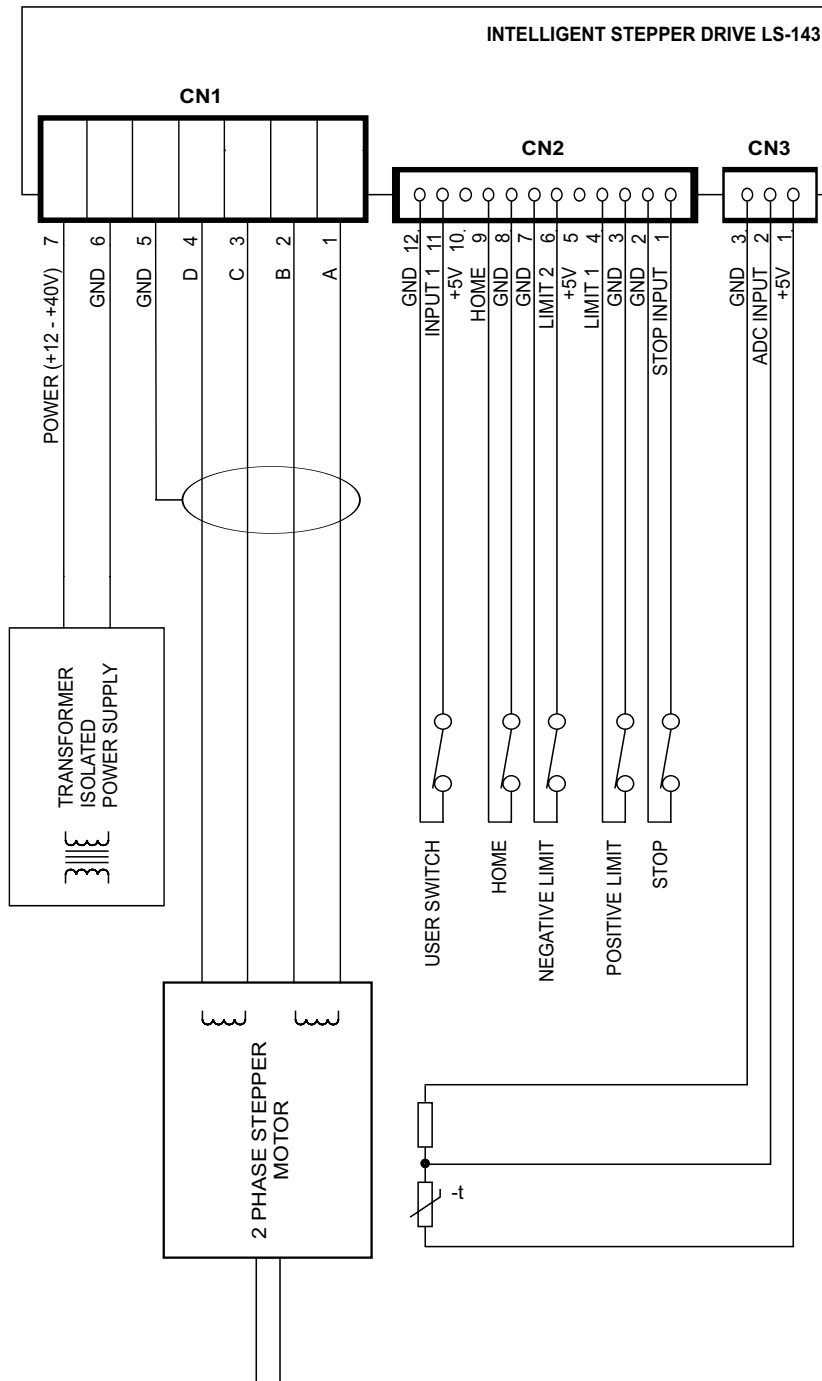

# Logosol Intelligent Stepper Drive LS-143

Doc. # 712143001 / Rev. 1.6, 10/02/2000

## LOGOSOL LS-143 QUICK START GUIDE

### Hardware Setup

1. Connect power supply (12 to 40 VDC) to LS-143.
2. Connect your motor and any other I/O you may have.
3. Connect RS-232 adapter and RJ-45 network cable between LS-143 and your host computer.

### Software Installation

#### 1. Installation and using Logosol Distributed Control Network Utility

##### A. Installation

1. Insert the Logosol Distributed Control Network Utility installation disk into the floppy drive.
2. Select Run from the Windows 95/98/NT Start menu.
3. Type a:\dcnsetup and then click OK (a: represents the drive letter).
4. The installation wizard will guide you through the setup process.

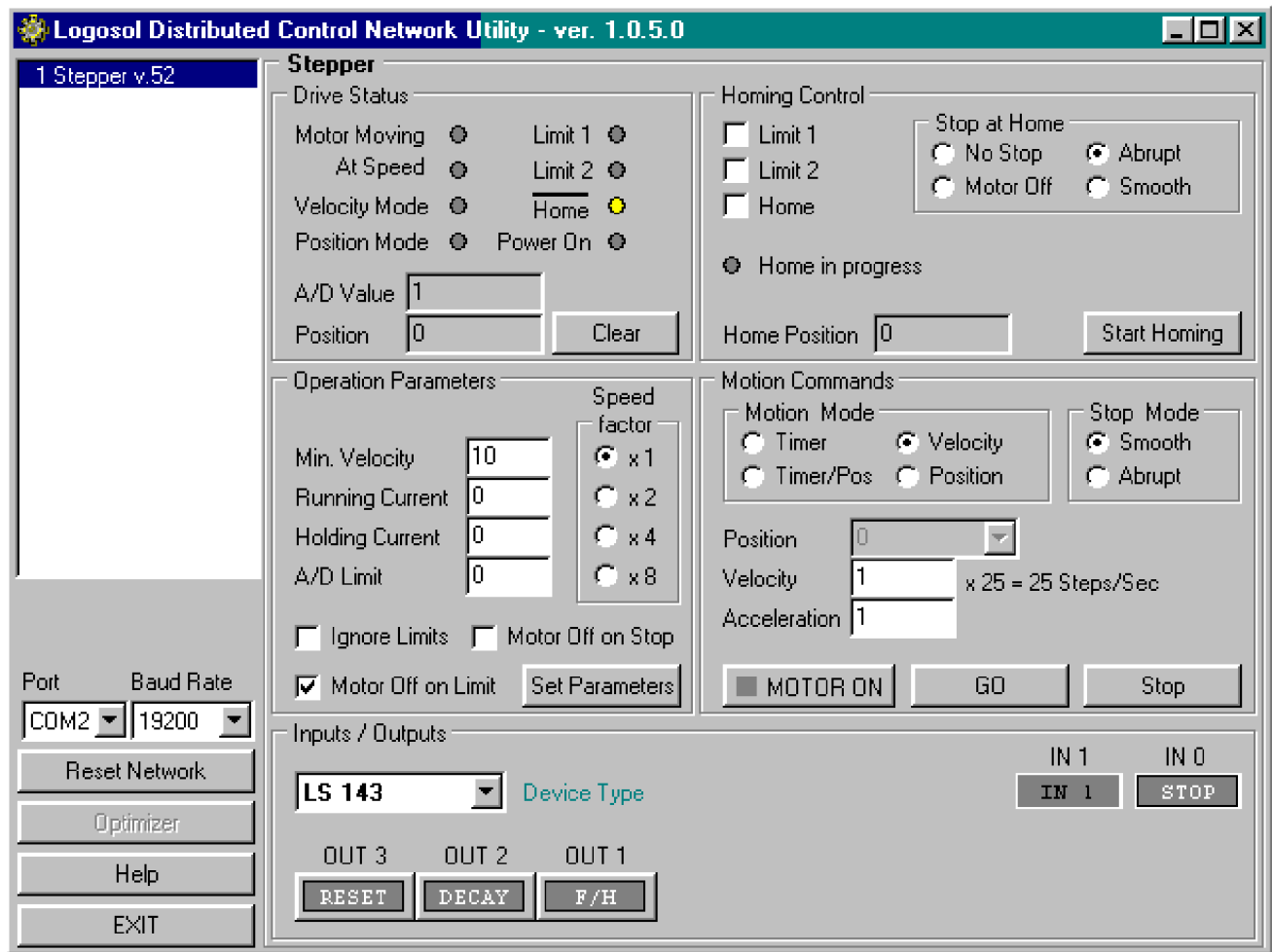

# Logosol Intelligent Stepper Drive LS-143

Doc. # 712143001 / Rev. 1.6, 10/02/2000

## B. Initial Connection to the Host

1. Turn on the power supply.
2. Run the Logosol Distributed Control Network Utility.
3. Choose the proper COM port
4. Click "MOTOR ON" button.
5. Click "GO" button. The motor should rotate slowly in positive direction. Click "Stop" to interrupt the motion. More information about using LDCN utility is available in LDCN Help.

## 2. Installation and using Logosol Motion Control Center

### A. Installation

1. Insert the Logosol Motion Control Center installation disk into the floppy drive.
2. Select Run from the Windows 95/98/NT Start menu.
3. Type a:\mccsetup and then click OK (a: represents the drive letter).
4. The installation wizard will guide you through the setup process.

### B. Initial Connection to the Host

1. Turn on the power supply.
2. Run the Logosol Motion Control Center software.
3. From the **Connection** menu select **Terminal**. This will open a terminal window. From the **Target** pull-down list select either RS-485-COM1 or RS-485-COM2 corresponding to the one used to communicate with LS-143. It may take few seconds to establish the communication.
4. Set the velocity and acceleration by the following commands: **VEL A1=5**, **ACC A1=100**. If desired, set the running and holding motor current limits using **RCL A1=20**, **HCL A1=10**. The default value for both current limits is 0, corresponding to about 0.6A. See *Current Control* section later in this document for details.
5. Type **FOR A1** to instruct the controller to rotate the motor forward. Type **GO A1** to initiate the motion. The motor should rotate slowly in positive direction. Type **STO** to interrupt the motion and refer to the following MCL\* Terminal Interpreter Command Set for executing various motion commands and parameters settings.

## MCL TERMINAL INTERPRETER COMMAND SET

**TMM** - returns and sets timer mode (speed factor):

- 1) **"TMM"** returns timer mode of all the axes;
- 2) **"TMM A1"** returns timer mode of axis A1;
- 3) **"TMM A1=Y"** sets timer mode of axis A1 to the specified value. Possible values are 1, 2, 4 and 8.

**ILS** - returns and sets ignore limit switch state:

- 1) **"ILS"** returns limit switch state of all the axes;
- 2) **"ILS A1"** returns limit switch state of axis A1;
- 3) **"ILS A1=Y"** sets limit switch state of axis A1 to the specified value. Possible values are Y (Yes) and N (No).

\* The information about MCL Terminal Interpreter command set is also available in MCC Help Menu Index (Advanced Features /Command set for Distributed Stepper Drive maintenance).



# Logosol Intelligent Stepper Drive LS-143

Doc. # 712143001 / Rev. 1.6, 10/02/2000

**MOS** - returns and sets "turn motor off on stop switch" state:

- 1) **"MOS"** returns the state of all the axes;
- 2) **"MOS A1"** returns the state of axis A1;
- 3) **"MOS A1=Y"** sets the state of axis A1 to the specified value. Possible values are Y (Yes) and N (No).

**MOL** - returns and sets "turn motor off on limits" state:

- 1) **"MOL"** returns the state of all the axes;
- 2) **"MOL A1"** returns the state of axis A1;
- 3) **"MOL A1=Y"** sets the state of axis A1 to the specified value. Possible values are Y (Yes) and N (No).

**MPV** - returns and sets minimum profile velocity value:

- 1) **"MPV"** returns minimum profile velocity of all the axes;
- 2) **"MPV A1"** returns minimum profile velocity of axis A1;
- 3) **"MPV A1=Y"** sets minimum profile velocity of axis A1 to the specified value Y (range 1 - 250).

**RCL** - returns and sets running current limit value:

- 1) **"RCL"** returns running current limit of all the axes;
- 2) **"RCL A1"** returns running current limit of axis A1;
- 3) **"RCL A1=Y"** sets running current limit of axis A1 to the specified value Y (range 0 - 255).

**HCL** - returns and sets holding current limit value:

- 1) **"HCL"** returns holding current limit of all the axes;
- 2) **"HCL A1"** returns holding current limit of axis A1;
- 3) **"HCL A1=Y"** sets holding current limit of axis A1 to the specified value Y (range 0 - 200).

*Note:* Holding current limit must be less than running current limit.

**THL** - returns and sets thermal limit value:

- 1) **"THL"** returns thermal limit of all the axes;
- 2) **"THL A1"** returns thermal limit of axis A1;
- 3) **"THL A1=Y"** sets thermal limit of axis A1 to the specified value Y (range 0 - 255).

**ITC** - returns and sets initial timer count value:

- 1) **"ITC"** returns initial timer count of all the axes;
- 2) **"ITC A1"** returns initial timer count of axis A1;
- 3) **"ITC A1=Y"** sets initial timer count of axis A1 to the specified value Y (range 0 - 65452).

# Logosol Intelligent Stepper Drive LS-143

Doc. # 712143001 / Rev. 1.6, 10/02/2000

**CLV** - returns and sets closest velocity value:

- 1) **"CLV"** returns closest velocity of all the axes;
- 2) **"CLV A1"** returns closest velocity of axis A1;
- 3) **"CLV A1=Y"** sets closest velocity of axis A1 to the specified value Y (range 1 - 255).

**PPM** - executes position profile mode (trapezoidal) motion:

**"PPM A1 P S A"** sends a motion command to axis A1 with target position P, speed S and acceleration A.

**VPM** - executes velocity profile mode motion:

**"VPM A1 S A"** sends a motion command to axis A1 with speed S and acceleration A.

**PUM** - executes position unprofiled mode motion:

**"PUM A1 P T C"** sends a motion command to axis A1 with target position P, initial timer count value T and closest velocity C.

**VUM** - executes velocity unprofiled mode motion:

**"VUM A1 T C"** sends a motion command to axis A1 with initial timer count value T and closest velocity C.

**HSW** - finds home switch:

- 1) **"HSW A1 F"** finds home switch of axis A1 in forward direction;
- 2) **"HSW A1 R"** finds home switch of axis A1 in reverse direction.

**POS** - returns and sets current position:

- 1) **"POS"** returns the positions of all the axes;
- 2) **"POS A1"** returns the position of axis A1;
- 3) **"POS A1=Y"** sets the position of axis A1 to the specified value Y.

**VEL** - returns and sets velocity in velocity profile mode or goal velocity in position (trapezoidal) profile mode:

- 1) **"VEL"** returns the velocities of all the axes;
- 2) **"VEL A1"** returns the velocity of axis A1;
- 3) **"VEL A1=Y"** set the velocity of axis A1 to the specified value Y.

**ACC** - returns and sets acceleration time:

- 1) **"ACC"** returns the accelerations of all the axes;
- 2) **"ACC A1"** returns the acceleration of axis A1;
- 3) **"ACC A1=Y"** set the acceleration of axis A1 to the specified value Y.

# Logosol Intelligent Stepper Drive LS-143

Doc. # 712143001 / Rev. 1.6, 10/02/2000

**XST** - displays status information:

- 1) "**XST**" displays status info for all the modules in the network;
- 2) "**XST A1**" displays status info for module A1.

Status information for the module includes:

- 1) Address
- 2) Status byte
- 3) Step time value
- 4) Inputs
- 5) Port B
- 6) Position
- 7) Device ID
- 8) Version

**STA** - displays MCL compatible status:

- 1) "**STA**" returns MCL compatible status of all the axes;
- 2) "**STA A1**" returns MCL compatible status of axis A1.

Note: Status 00000400 - position reached;  
00000080 - servo off.

**INI** - resets the network and assigns individual addresses if necessary.

**STO** - stops abruptly:

- 1) "**STO**" stops the movement of all the axes;
- 2) "**STO A1**" stops the movement of axis A1.

**HAL** - stops smoothly with specified acceleration:

- 1) "**HAL**" stops the movement of all the axes;
- 2) "**HAL A1**" stops the movement of axis A1.

**ABS** - sets absolute motion position for specified axis - "**ABS A1=Y**".

**REL** - sets relative motion position for specified axis - "**REL A1=Y**".

**FOR** - sets forward motion in velocity mode:

- 1) "**FOR A1**" sets the motion of axis A1 with the current speed;
- 2) "**FOR A1=Y**" sets the motion of axis A1 with the specified speed Y.

**REV** - sets reverse motion in velocity mode:

- 1) "**REV A1**" sets the motion of axis A1 with the current speed;
- 2) "**REV A1=Y**" sets the motion of axis A1 with the specified speed Y.

**GO** - starts motion:

- 1) "**GO**" starts motion of all axes;
- 2) "**GO A1**" starts motion of axis A1.

**SER** - turns motor on:

- 1) "**SER**" turns motor on of all connected modules;
- 2) "**SER A1**" turns motor on of module A1.

# Logosol Intelligent Stepper Drive LS-143

---

Doc. # 712143001 / Rev. 1.6, 10/02/2000

**NOS** - turns motor off:

- 1) **"NOS"** turns motor off of all connected modules;
- 2) **"NOS A1"** turns motor off of module A1.

**FLS** - finds limit switch:

- 1) **"FLS A1 F"** finds limit switch of axis A1 in forward direction;
- 2) **"FLS A1 R"** finds limit switch of axis A1 in reverse direction.

**HEX** - hex command mode:

**"HEX 1 05"** executes Start Motion command (code 0x05) for module #1. For more information refer to "Command Description" section in Logosol AC/DC Intelligent Stepper Drive documentation. Start byte (AA) and checksum byte are generated by the MCL interpreter.

**BDR** - sets baud rate:

**"BDR 115200"** - sets baud rate to 115.2Kbps.

*Note: baud rate is set to 19.2Kbps after power-up.*

**HIS** - shows the history of the last used commands, their hexadecimal codes and the returned status bytes.

**EXE** - executes user-defined file containing sequence of MCL commands.

**"EXE control.dat"** - executes the command sequence from "control.dat" file from work or MCC directory.

**VER** - returns MCL interpreter version.

**NET** - displays number and types of all the modules in the network and their addresses.

# Logosol Intelligent Stepper Drive LS-143

Doc. # 712143001 / Rev. 1.6, 10/02/2000

## LS-143 ARCHITECTURE

### Overview

The LS-143 Intelligent Stepper Drive is fully integrated device including high speed step and direction motion controller and up to 3A full step/half step power driver working in chopper (constant current) mode. It supports RS-232 or multi-drop RS-485 serial interface using the same communications protocol as the other members of Logosol Distributed Motion Control Network. LS-143 supports velocity and trapezoidal position mode, using a 32-bit position counter. It features five digital inputs - positive and negative limits, home, stop and one general-purpose. One analog input with 8-bit ADC is available for either thermal protection or general-purpose measurements.

A network of up to 31 controllers can be connected directly to a single standard serial port (RS-232 adapter may be necessary).

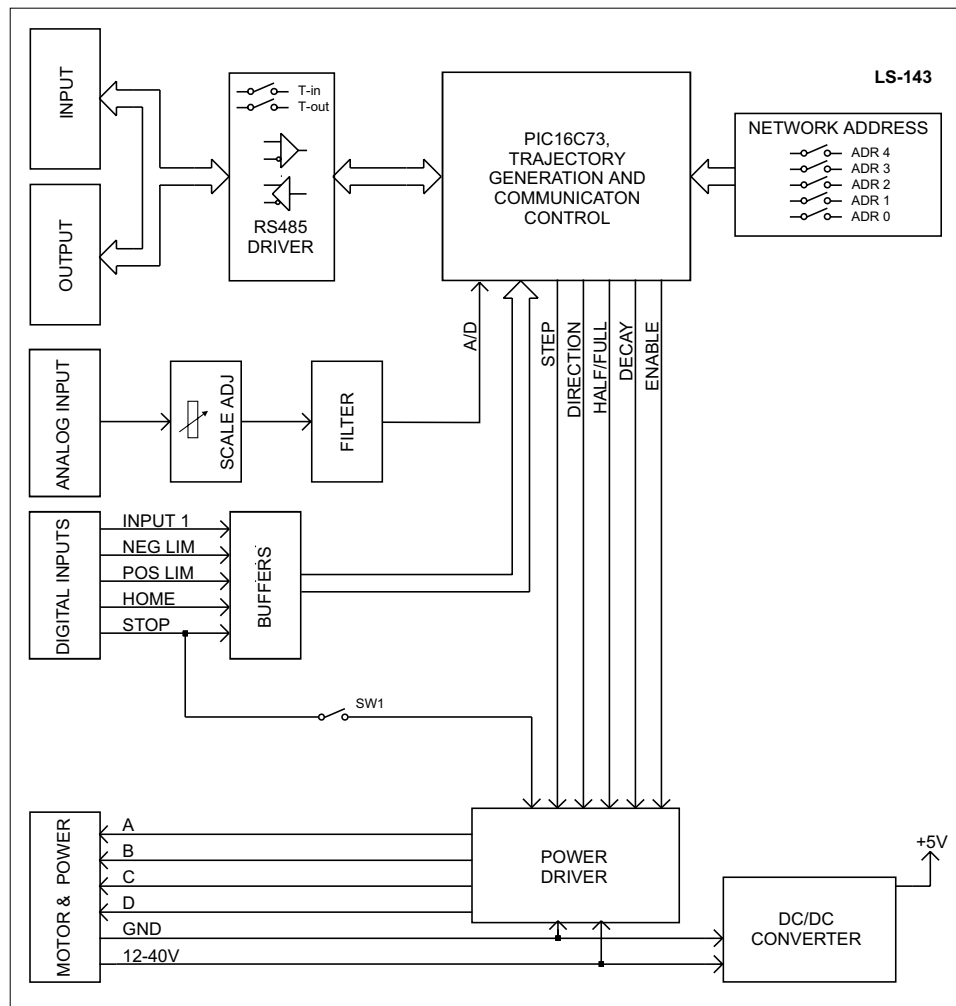

Functional Diagram

# Logosol Intelligent Stepper Drive LS-143

Doc. # 712143001 / Rev. 1.6, 10/02/2000

## Digital Inputs

There are five digital inputs - STOP, LIMIT 1, LIMIT 2, HOME, INPUT 1. Each input has internal pull-up resistor to +5V and a diode in series. This allows the inputs to endure up to 48V input voltage. The threshold, however, remains at TTL level:  $0 \leq \text{LOW} \leq 1.2\text{V}$ ,  $2.8\text{V} \leq \text{HIGH} \leq 48\text{V}$ .

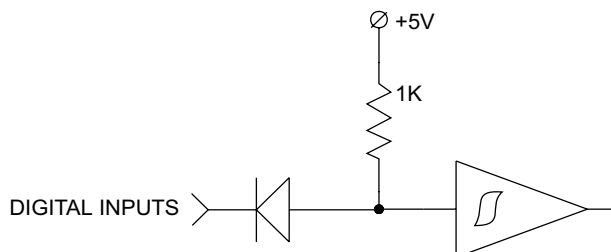

**STOP** is intended for use as an emergency stop. It stops abruptly the motor regardless of the direction. To activate the STOP input it has to be open or tied to HIGH. Closing STOP input to the ground enables the motor. If the motor is running and the STOP input is activated the current motion profile is cleared.

To resume motion after Stop condition a new trajectory should be specified followed by GO command.

- **LIMIT 1** serves as positive limit input. It inhibits any motor motion in positive direction and optionally turns off the motor. Motion in negative direction is allowed (if the motor is not turned off). The limit function may be disabled and the input may be used for homing or as general-purpose input. When the limit function is enabled, LIMIT 1 has to be closed to the ground to allow the motor movement. Leaving it open or tying it to HIGH activates the function.
- **LIMIT 2** serves as negative limit input. It works similar to LIMIT 1 but in negative direction.
- **HOME** input is used for homing the system. In order to obtain reliable and repeatable home position, the HOME input is internally AND-ed with AT FULL STEP signal from the drive. The home position latching is performed on the first occurrence of AT FULL STEP, when the HOME input is found open or tied to HIGH. Bit 5 in *Input byte* is cleared when HOME input is HIGH and drive is AT FULL STEP, and is set otherwise.
- **INPUT 1** is non-dedicated general-purpose input.

# Logosol Intelligent Stepper Drive LS-143

Doc. # 712143001 / Rev. 1.6, 10/02/2000

## Analog Input

LS-143 features one analog input equipped with 8-bit ADC. The input full scale is adjustable in the range of 0.5V to 30V. LS-143 may be programmed to automatically shut off the motor at certain analog input level. The primary application of that feature is a motor thermal protection. With external thermistor bridge LS-143 may automatically turn off the motor to prevent overheating. Thermistors with either positive or negative temperature coefficient may be used. The threshold may be set at any value between 0 and 255. If it is set to an even value (2, 4, 6, etc), the motor will shut down when A/D value is less than the threshold. If the threshold is odd (1, 3, 5, etc), the shutdown will occur when the A/D value is greater than that value. Setting threshold to 0 effectively disables shutdown feature. The analog input may be read at any time, it doesn't matter whether the shutdown feature is enabled or not.

## Motor Current Control

LS-143 works in chopper (constant current) mode. It drives the motor with constant current independent of the power supply and the motor speed. The motor current has two separate programmable levels – running (RCL) and holding (HCL). The switching between them is performed automatically. The running current may be set from 0 (minimum) to 255 (maximum). The maximum value for the holding current is 200. In addition, the holding current cannot be higher than the running current. If an attempt to exceed the holding current boundaries is made, the actual holding current will be set equal to 200 or to the running current (the lesser of them). The correspondence between the programmed value and the actual motor current is shown in the following table:

RCL/HCL* value	MOTOR RUNNING CURRENT [A]	MOTOR HOLDING CURRENT [A]
0	0.6	0.6
25	0.8	0.8
50	1.1	1.1
75	1.4	1.4
100	1.8	1.8
125	2.0	2.0
150	2.3	2.3
175	2.5	2.5
200	2.8	2.8
225 and over	3.0	

# Logosol Intelligent Stepper Drive LS-143

Doc. # 712143001 / Rev. 1.6, 10/02/2000

## Mode Control Outputs

LS-143 has three internal control signals used to select the desired mode of operation.

- **OUT3 – Reset.** OUT3 set to ON puts the Stepper Drive in reset and the motor is positioned AT FULL STEP – both motor windings are energized, the AB winding current is from A to B, the CD winding current is from C to D. To run the motor OUT3 must be OFF.
- **OUT2 – Decay.** With OUT2 set to ON, LS-143 operates in Fast Decay mode. For Slow Decay mode OUT2 should be OFF.
- **OUT1 – F/H.** With OUT1 OFF LS-143 operates in Half Step mode (HS). To run in Full Step mode (FS), OUT1 should be ON. Switching between Full Step and Half Step mode must be performed only with Reset signal ON:

MODE	OUT3	OUT1
Reset	ON	X
HS Set	ON	⌋
HS Run	OFF	OFF
FS Set	ON	⌋
FS Run	OFF	ON

## DIP Switch

A DIP switch is used for setting the individual address and terminator. Two of the switches T-in and T-out, are used to turn ON/OFF receive and transmit lines terminators.

SW1 is reserved for future applications and must be OFF.

The rest of DIP switches - ADDR4 to ADDR0 are used to set the device address. See **Addressing** further in this manual.



# Logosol Intelligent Stepper Drive LS-143

## Serial Command Interface

Serial communication with the LS-143 drives adheres to a full-duplex (4 wire) 8 bit asynchronous protocol with one start bit, followed by 8 data bits (LSB first), followed by a single stop bit.

The communication protocol of the LS-143 also supports a full-duplex multi-drop RS-485 interface that allows multiple LS-143 intelligent stepper drives to be controlled over a single RS-485 port. In this case, the host sends commands over its RS-485 transmit line and receives all status data back over the shared RS-485 receive line.

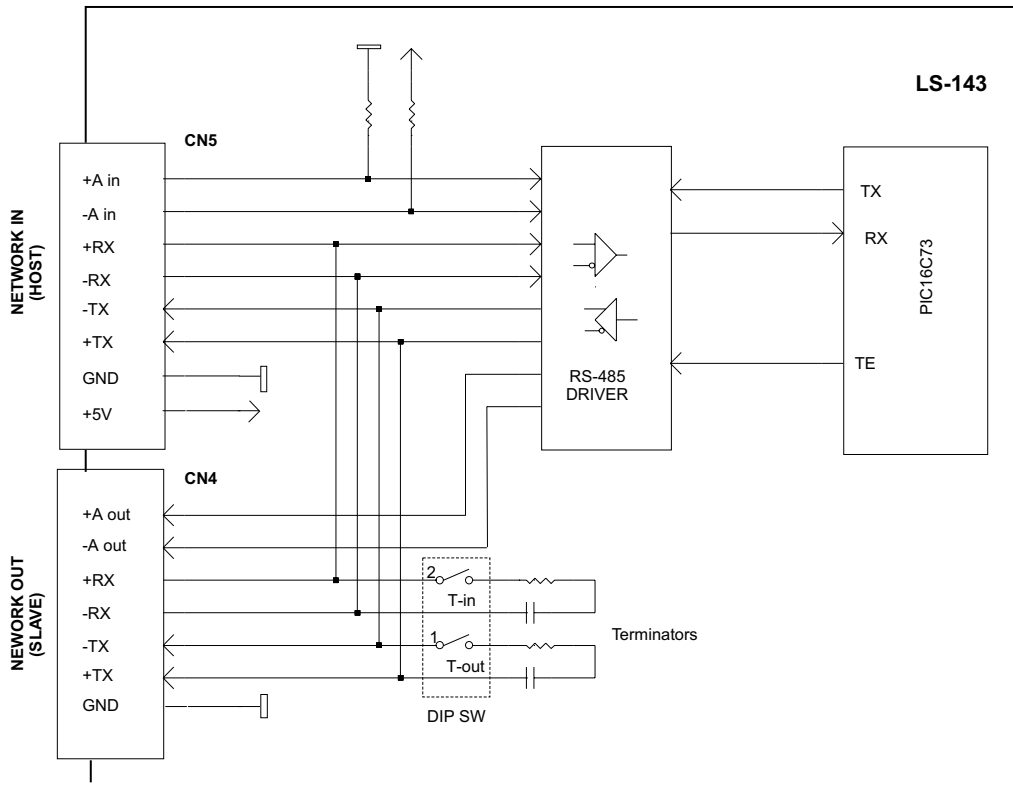

Stepper Drive Serial Interface

The command protocol is a strict master/slave protocol in which the host master sends a command packet over the command line to a specific LS-143 slave. The data are stored in the buffer of the LS-143 until the end of the current cycle (0.512 msec max.) and then the command is executed. The servo drive then sends back a status packet. Typically, the host does not send another command until a status packet has been received to insure that it does not overwrite any previous command data still in use.

# Logosol Intelligent Stepper Drive LS-143

Doc. # 712143001 / Rev. 1.6, 10/02/2000

Each command packet consists of following:

- Header byte (0xAA)*
- Address byte - individual or group (0x00 - 0xFF)*
- Command byte*
- 0 - 15 data bytes*
- Checksum byte*

The command byte is divided into upper and lower nibbles: the lower nibble is the command value; the upper nibble is the number of additional data bytes, which will follow the command byte. The checksum byte is 8-bit sum of the address byte, the command byte and the data bytes. The number of data bytes depends on the particular command chosen. After a command is issued, the corresponding controller will send back a status packet consisting of:

- Status byte*
- 0-16 optional bytes of status data*
- Checksum byte*

The status byte contains basic status information about the LS-143, including a checksum error flag for the command just received. The optional data bytes may include data such as the position, velocity, etc. and are programmable by the host. The checksum byte is the 8 bit sum of the status byte and the additional optional status data bytes. All 16-bit and 32-bit data is send the least significant byte first.

## Multiple Controller Configuration

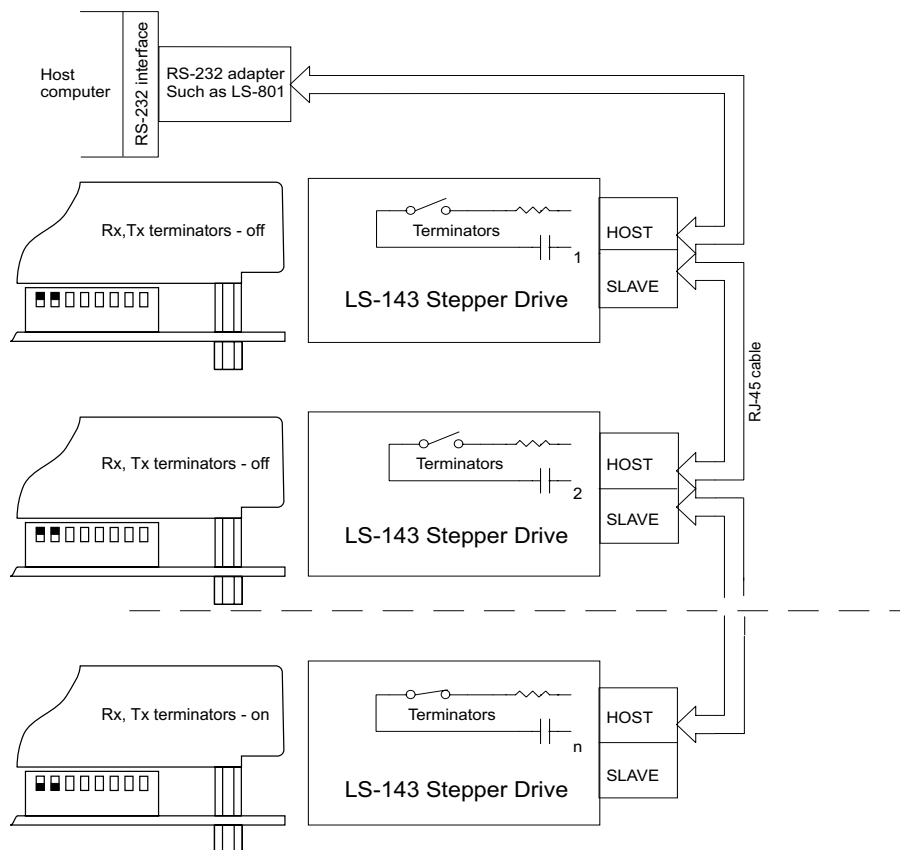

# Logosol Intelligent Stepper Drive LS-143

Doc. # 712143001 / Rev. 1.6, 10/02/2000

## Addressing

Network address may be assigned to LS-143 Stepper Drive in two ways – either hard-wired, or dynamically. In first case the address is set using DIP switches (see the figure below).

In case of dynamically address assignment the host sets the address of each LS-143 with the aid of the daisy-chained “A in” and “A out” lines. This allows additional LS-143 controllers to be added to an RS-485 network with no hardware changes. On power-up, “A in” of the first LS-143 is pulled low, its communication is enabled and the default address is 0x00. When the *Set Address* command is issued to give this LS-143 new unique address, it will lower its “A out” pin. Connecting “A out” pin to the “A in” pin of the next servo drive in the network will enable its communication at default address of 0x00. Repeating this process allows a variable number of controllers present to be given unique addresses.

Dynamic addressing:

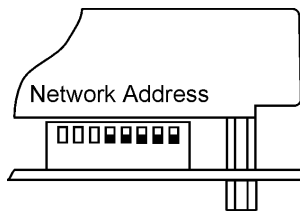

Hard-wired network address

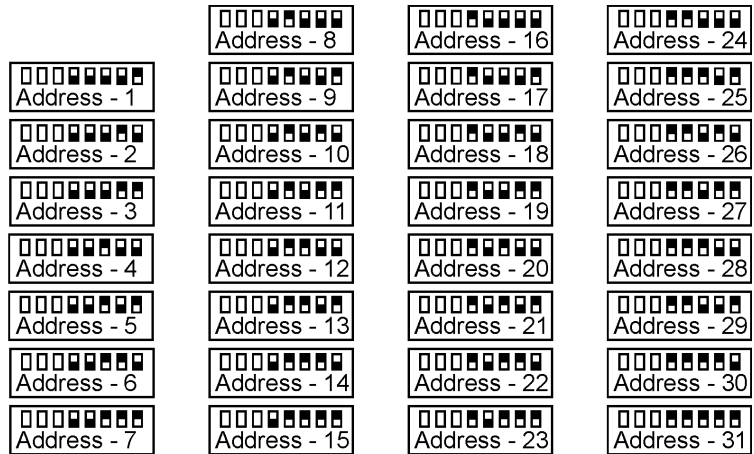
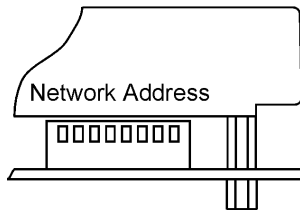

## Group Addresses

In addition to the individual address, each controller has a secondary group address. Several LS-143 controllers may share a common group address. This address is useful for sending commands, which must be performed simultaneously by a number of drivers (e.g. *Start motion*, *Set Baud Rate*, etc.). When a LS-143 receives a command sent to its group address, it will execute the command but not send back a status packet. This prevents data collisions on the shared response line. In programming group addresses, however, the host can specify that one member of the group is the “group leader”. The group leader will send back a status packet just like it would for a command sent to its individual address. The group address is programmed at the same time as the unique individual address using the *Set Address* command.

# Logosol Intelligent Stepper Drive LS-143

---

Doc. # 712143001 / Rev. 1.6, 10/02/2000

## Changing Communications Rates

The default baud rate after power-up is 19.2 Kbps. Baud rates up to 115.2 Kbps may be used at maximum servo rate. After communication has been established with all servo drives on a single network, the baud rate may be changed to a higher value with the *Set Baud Rate* command.

## Homing

The LS-143 Drive has built-in homing features for assisting in initializing the motor position. A special command is used to make the LS-143 start monitoring its limit switch inputs or its homing switch input. When one of the selected switch inputs next changes state, the motor's position will be stored in an internal homing register, and motor will optionally stop in one of three specified manners: 1) decelerating to a stop, 2) stopping abruptly, or 3) turning the motor off altogether.

Once the homing condition has occurred (as determined from the homing bit in the status byte), the home position can be read from the home position register using the *Read Status* command.

Note that the homing command does not actually start any movement of the motor. The homing command is first issued, and then a *Load Trajectory* command is used to start the motor moving in the desired direction.

# Logosol Intelligent Stepper Drive LS-143

Doc. # 712143001 / Rev. 1.6, 10/02/2000

## THEORY OF OPERATION

### **Unprofiled Motion - The Basic Step Timer**

The LS-143 Drive has an internal 16-bit timer, which is used to set the time between step pulses. In unprofiled operating modes, this timer is loaded with a user specified initial timer count. When the timer counts up and rolls over to a value of 0x0000, a 4.8 microsecond step pulse is generated, and the timer is reloaded with the initial timer count.

The step timer can be set to operate at one of four speeds. The 1x speed is 625,000 Hz, the 2x speed is 1,250,000 Hz, the 4x speed is 2,500,000 Hz, and the 8x speed is 5,000,000 Hz. The following formulas can be used to determine the initial timer count for a desired unprofiled stepping velocity, (**S**), in steps per second:

<b>Speed factor</b>	<b>Initial Timer Count</b>
1x	$2 + 65,536 - 625,000 / S$
2x	$4 + 65,536 - 1,250,000 / S$
4x	$8 + 65,536 - 2,500,000 / S$
8x	$16 + 65,536 - 5,000,000 / S$

Table 2: Determining Initial Timer Counts for Different Speed factors.

For example, in order to rotate the motor with 25 steps per second with speed factor 1x, 40538 must be used as initial timer counter:

$$2 + 65536 - 625000 / 25 = 65538 - 25000 = 40538$$

The initial timer count can be loaded using the Load Trajectory command described in the Command Reference section. The maximum allowable initial timer count is 65,452, and the minimum is 1.

In conjunction with the initial timer count, a stopping position can also be loaded using the Load Trajectory command. If a stopping position is loaded, the motor will move at the unprofiled stepping velocity until it reaches the stop position, at which point it will stop abruptly. This mode is referred to as the *position unprofiled mode*.

*Note:* To change the direction of motion, a stop command must first be issued before a velocity in the opposite direction is commanded.

# Logosol Intelligent Stepper Drive LS-143

Doc. # 712143001 / Rev. 1.6, 10/02/2000

## Velocity Profile Mode

Velocity profile mode is used to smoothly accelerate from one velocity to another. Instead of using initial timer count values, however, velocities are specified as integer values (**S**) between 1 and 250. Step rate multipliers, minimum and maximum velocities for the different speed factors appear in the table below:

<b>Speed factor</b>	<b>Step Rate Multiplier (K) in steps/sec.</b>	<b>Minimum Step Rate S = 1 in steps/sec.</b>	<b>Maximum Step Rate S = 250 in steps/sec.</b>
1x	25	25	6,250
2x	50	50	12,500
4x	100	100	25,000
8x	200	200	50,000

Table 3: Step rate multipliers and Maximum Velocities for Different Speed factors. The actual velocity **V** in steps per second can be obtained using the formula:

$$V = S * K, \text{ in steps per second}$$

where

- S** is integer velocity value (range 1 - 250) and  
**K** is the step rate multiplier (see Table 3)

The acceleration or deceleration is achieved by incrementing (or decrementing) the current integer velocity value by one until the goal velocity is reached. The actual time for acceleration from one velocity to another can be obtained using the formula:

$$T_{acc} = | (64 - 0.25 * Acc) * (S_{tar} - S_{cur}) | \text{ in ms,}$$

where

- Acc** is the acceleration value (range 1 - 255),  
**S<sub>cur</sub>** is current velocity value (range 1 - 250),  
**S<sub>tar</sub>** is target velocity value (range 1 - 250), and  
**T<sub>acc</sub>** is the time to accelerate from velocity **S<sub>cur</sub>** to **S<sub>tar</sub>** with acceleration **Acc**

Examples:

1. Accelerating from current velocity 25 to target velocity 125 with acceleration 100.  
**S<sub>cur</sub>** = 25, **S<sub>tar</sub>** = 125, **Acc** = 100.  
 $| (64 - 0.25 * 100) * (125 - 25) | = | 39 * 100 | = | 3900 | = 3900 \text{ ms (3.9 s)}$
2. Decelerating from current velocity 125 to target velocity 25 with acceleration 100.  
**S<sub>cur</sub>** = 125, **S<sub>tar</sub>** = 25, **Acc** = 100.  
 $| (64 - 0.25 * 100) * (25 - 125) | = | 39 * (-100) | = | -3900 | = 3900 \text{ ms (3.9 s)}$

*Note:* To change the direction of motion, a stop command must first be issued before a velocity in the opposite direction is commanded.

Do not use velocity values less than minimum profile velocity (see *Set parameters* command).

# Logosol Intelligent Stepper Drive LS-143

Doc. # 712143001 / Rev. 1.6, 10/02/2000

## Position (Trapezoidal) Profile Mode

Trapezoidal profile mode is used to move to a goal position by first accelerating up to a running velocity, slewing at the running velocity, and finally decelerating to a stop at the commanded goal position.

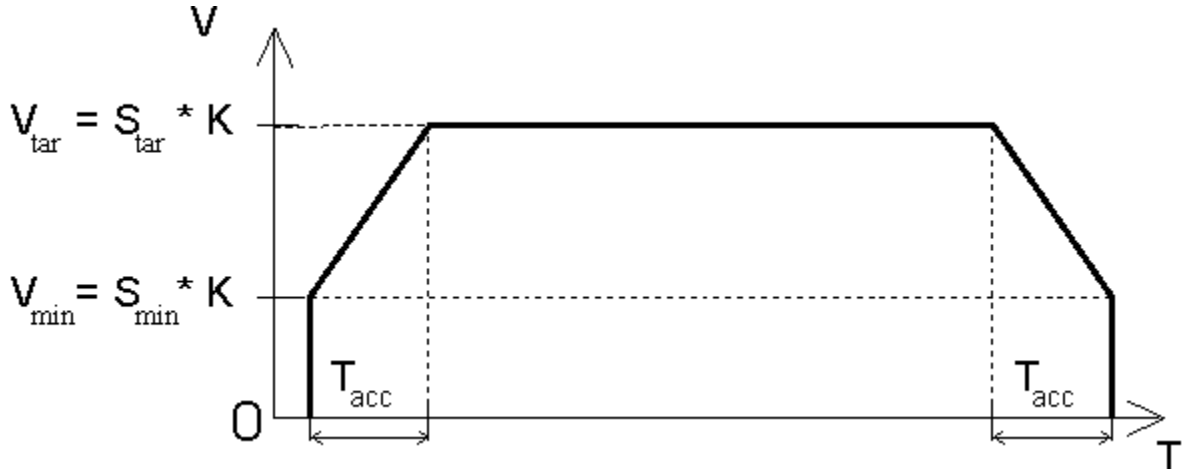

The actual time for acceleration to velocity  $S_{tar}$  can be obtained using the formula:

$$T_{acc} = (64 - 0.25 * Acc) * (S_{tar} - S_{min}) \text{ in ms,}$$

where

**Acc** is the acceleration value (range 1 - 255),

**S<sub>min</sub>** is minimum profile velocity value (range 1 - 250),

**S<sub>tar</sub>** is target velocity value (range 1 - 250), and

**T<sub>acc</sub>** is the time to accelerate from velocity value **0** to **S<sub>tar</sub>** with acceleration **Acc**

Example:

1. Accelerating to velocity 125 with minimum profile velocity 25 and acceleration 100.

$$S_{min} = 25, S_{tar} = 125, Acc = 100.$$

$$| (64 - 0.25 * 100) * (125 - 25) | = | 39 * 100 | = | 3900 | = 3900 \text{ ms (3.9 s)}$$

*Note:* Do not use velocity values less than minimum profile velocity (see *Set parameters* command).

# Logosol Intelligent Stepper Drive LS-143

Doc. # 712143001 / Rev. 1.6, 10/02/2000

## Changing different motion modes

Table 4 bellow details which goal modes can be entered from any starting mode, and which data needs to be loaded in order to enter a given goal mode.

Table 4 - Operating Mode Transition Table:

Goal Mode	Starting Mode				
	Stopped	Position Profile trapezoidal	Velocity Profile	Position Unprofiled	Velocity Unprofiled
Stopped	---	Use Stop Command	Use Stop Command	Use Stop Command	Use Stop Command
Position Profile trapezoidal	✓ Position ○ Velocity ○ Acceleration × Tmr. Count	Not Allowed	Not Allowed	Not Allowed	Not Allowed
Velocity Profile	× Position ○ Velocity ○ Acceleration × Tmr. Count	× Position ○ Velocity ○ Acceleration × Tmr. Count	× Position ○ Velocity ○ Acceleration × Tmr. Count	× Position ○ Velocity ○ Acceleration × Tmr. Count	× Position ○ Velocity ○ Acceleration × Tmr. Count
Position Unprofiled	✓ Position × Velocity × Acceleration ✓ Tmr. Count	✓ Position × Velocity × Acceleration ✓ Tmr. Count	Not Allowed	✓ Position × Velocity × Acceleration ✓ Tmr. Count	Not Allowed
Velocity Unprofiled	× Position × Velocity × Acceleration ✓ Tmr. Count	Not Allowed	× Position × Velocity × Acceleration ✓ Tmr. Count	Not Allowed	× Position × Velocity × Acceleration ✓ Tmr. Count

✓ Load this parameter

× Do not load this parameter

○ Optionally load this parameter

*If a parameter is not loaded, the previously loaded value will be used.*



# Logosol Intelligent Stepper Drive LS-143

Doc. # 712143001 / Rev. 1.6, 10/02/2000

## COMMAND SPECIFICATION

### List of Commands

Command	CMD Code	# Data bytes	Description	While Moving?
Reset position	0x0	0	Sets position counter to zero	No
Set address	0x1	2	Sets the individual and group addresses	Yes
Define status	0x2	1	Defines which data should be sent in every status packet	Yes
Read status	0x3	1	Causes particular status data to be returned just once	Yes
Load trajectory	0x4	1-9	Loads motion trajectory parameters	Maybe
Start motion	0x5	0	Executes the previously loaded trajectory	Maybe
Set parameters	0x6	5	Sets the motion parameters and operating limits	Yes
Motor ON / stop	0x7	1	Stops the motor in one of three manners	Yes
I/O control	0x8	1	Sets the output values	Yes
Set home mode	0x9	1	Sets conditions for capturing the home position	Yes
Set baud rate	0xA	1	Sets the baud rate	Yes
Reserved	0xB			
Save as home	0xC	0	Saves the current position in the home position register	Yes
Reserved	0xD			
Nop	0xE	0	Simply causes the defined status data to be returned	Yes
Hard reset	0xF	0	Resets the controller to its power-up state.	Yes

## LS-143 Command Description

### Reset Position

Command value: 0x0  
Number of data bytes: 0  
Command byte: 0x00

### Description:

Resets the 32-bit internal position counter to 0. Do not issue this command while the motor is in motion.

### Set Address

Command value: 0x1  
Number of data bytes: 2  
Command byte: 0x21  
Data bytes:

1. Individual address: 0x01-0x7F (initial address 0x00)
2. Group Address: 0x80-0xFF (initial value 0xFF)

### Description:

Sets the individual address and group address. Group addresses are always interpreted as being between 0x80 and 0xFF. If a Drive is to be a group leader, clear bit 7 of the desired group address in the second data byte. The Step device will automatically set bit 7 internally after flagging the Drive as a group leader (If bit 7 of the second data byte is set, the module will be a group member by default). The first time this command is issued after power-up or reset, it will also enable communications for the next Drive in the network chain by lowering its "A out" signal.

# Logosol Intelligent Stepper Drive LS-143

Doc. # 712143001 / Rev. 1.6, 10/02/2000

## Define Status

Command value: 0x2  
Number of data bytes: 1  
Command byte: 0x12

### Data bytes:

#### 1. Status items: (default: 0x00)

Bit 0: send position (4 bytes)  
1: send A/D value (1 byte)  
2: send current step period (2 bytes)  
3: send input byte (1 byte)  
4: send home position (4 bytes)  
5: send device ID and version number (2 bytes)  
(motor controller device ID = 3, version number = 50 - 95)  
6: send I/O state byte  
7: not used

### Description:

Defines what additional data will be sent in the status packet along with the status byte. Setting bits in the command's data byte will cause the corresponding additional data bytes to be sent after the status byte. The status data will always be sent in the order listed. For example if bits 0 and 3 are set, the status packet will consist of the status byte followed by four bytes of position data, followed by the input byte, followed by the checksum. The status packet returned in response to this command will include the additional data bytes specified. On power-up or reset, the default status packet will include only the status byte and the checksum byte.

## Read Status

Command value: 0x3  
Number of data bytes: 1  
Command byte: 0x13

### Data bytes:

#### 1. Status items:

Bit 0: send position (4 bytes)  
1: send A/D value (1 byte)  
2: send current step period (2 bytes)  
3: send input byte (1 byte)  
4: send home position (4 bytes)  
5: send device ID and version number (2 bytes)  
(motor controller device ID = 3, version number = 50 - 59)  
6: send I/O state byte  
7: not used

### Description:

This is a non-permanent version of the *Define Status* command. The status packet returned in response to this command will incorporate the data bytes specified, but subsequent status packets will include only the data bytes previously specified with the *Define Status* command.

Note: The actual velocity is a positive number when moving in reverse direction and a negative number when moving in forward direction.

# Logosol Intelligent Stepper Drive LS-143

Doc. # 712143001 / Rev. 1.6, 10/02/2000

## Load Trajectory

Command value: 0x4  
Number of data bytes:  $n = 1-9$   
Command byte: 0xn4

Data bytes:

1. Control byte:

Bit	0:	load position data ( $n = n + 4$ bytes)
	1:	load velocity data ( $n = n + 1$ byte)
	2:	load acceleration data ( $n = n + 1$ bytes)
	3:	load initial timer count (2 bytes) and closest velocity value (1 byte) ( $n = n + 3$ bytes)
	4:	direction - 0 = positive, 1 = negative
	5,6	not used
	7	start motion now

### Description:

All motion parameters are set with this command. Setting one of the first four bits in the control byte will require additional data bytes to be sent (as indicated) in the order listed. The position data (range +/- 0x7FFFFFFF) is only used as the goal position in position profile or unprofiled mode. The velocity data (range 1 to 250) is used as the goal velocity in velocity profile mode or as the maximum velocity in trapezoidal profile mode and must be greater than or equal to minimum profile velocity parameter. The acceleration data (range 1 to 255) is used in both trapezoidal and velocity profile mode.

The initial timer count (range 1 to 65452) is used to set the time between step pulses in position or velocity unprofiled mode. This value is loaded in an internal counter and when the internal timer counts up and rolls over to a value of 0000h, a 4.8 microsecond step pulse is generated, and the timer is reloaded with the initial timer value. The closest velocity value is used when switching from velocity unprofiled mode to velocity profile mode. This value will be used as the starting point for the ramping.

Bit 4 indicates the velocity direction and is ignored in trapezoidal profile mode or position unprofiled mode.

## Start Motion

Command value: 0x5  
Number of data bytes: 0  
Command byte: 0x05

### Description:

Causes the trajectory information loaded with the most recent Load Trajectory command to execute. This is useful for loading several step devices with trajectory information and then starting them simultaneously with a group command.

---

\* While the position may range from -0x7FFFFFFF to +0x7FFFFFFF, the goal position should not differ from the current position by more than 0x7FFFFFFF.

# Logosol Intelligent Stepper Drive LS-143

Doc. # 712143001 / Rev. 1.6, 10/02/2000

## Set Parameters

Command value: 0x6

Number of data bytes: 5

Command byte: **0x56**

Data bytes:

1. Control byte:

Bit 1,0: speed factor 00 = 8x, 01 = 4x, 10 = 2x, 11 = 1x

2: disable limit switch autostop

3: turn motor off on limit switch

4: turn motor off on stop switch

5,6,7: not used

1. minimum profile velocity (1 – 250)

2. running current limit (0-255)

3. holding current limit (0-200)

4. thermal limit (0-255 – value of 0 disables limiting)

### Description:

Sets control parameters and limits governing the behavior of the motor. This command must be issued before any motion can be executed. If the thermal limit value is even, thermal shutdown will occur when the A/D value is less than the thermal limit. If the thermal limit is odd, thermal shutdown will occur when the A/D value is greater than the thermal limit.

### Notes:

The holding current limit must be less than the running current limit.

Do not use velocity values with *Load Trajectory* command less than minimum profile velocity.

Do not use this command to change speed factor or minimum profile velocity when the motor is moving.

## Motor ON / Stop

Command value: 0x7

Number of data bytes: 1

Command byte: **0x17**

Data bytes:

1. Stop control byte:

Bit 0: turn motor on/off

1: not used

2: stop abruptly

3: stop smoothly

4-7: not used - clear all to 0

### Description:

Turns motor ON / OFF or stops the motor in the specified manner. If bit 0 of the Stop Control Byte is set, the motor will be turned on. If bit 0 is cleared motor will be turned off, regardless of the state of the other bits. If bit 2 is set, the motor will stop moving abruptly. Setting bit 3 enters a more graceful stop mode - the motor will decelerate to a stop. Only one of bits 2 or 3 should be set at one time.

# Logosol Intelligent Stepper Drive LS-143

Doc. # 712143001 / Rev. 1.6, 10/02/2000

## Set Outputs

Command value: 0x8  
Number of data bytes: n=1  
Command byte: 0x18  
Data bytes:  
1. Set outputs control byte  
Bit 0-4: output values  
5-7: not used

### Description:

Immediately sets the values of outputs.

Note: Do not change OUT3 (Half / Full step mode) when OUT1 (Reset) is OFF.

## Set Homing Mode

Command value: 0x9  
Number of data bytes: 1  
Command byte: 0x19  
Data bytes:  
1. Homing control byte  
Bit 0: Capture home position on change of Positive Limit  
1: Capture home position on change of Negative Limit  
2 Turn motor off on home  
3: Capture home on change of home switch  
4: Stop abruptly on home  
5: Stop smoothly on home  
6,7 not used (clear to 0)

### Description:

Causes the Drive to monitor the specified conditions and capture the home position when any of the flagged conditions occur. The home\_in\_progress bit in the status byte is set when this command is issued and it is lowered when the home position has been found. Setting one (and only one) of bits 2, 4 or 5 will cause the motor to stop automatically in the specified manner once the home condition has been triggered. This feature can also be used as a safety shutoff.

## Set Baud Rate

Command value:	0xA	<b>sample values:</b>	
Number of data bytes:	1	9600	BRD = 0x81
Command byte:	0x1A	19200	BRD = 0x3F
Data bytes:		57600	BRD = 0x14
1. Baud rate divisor,	BRD	115200	BRD = 0x0A

### Description:

Sets the communication baud rate. All step drives on the network must have their baud rates changed at the same time; therefore this command should only be issued to a group including all of the controllers on the network. A status packet returned from this command would be at the new baud rate, so typically (unless the host's baud rate can be accurately synchronized) there should be no group leader when this command is issued.

# Logosol Intelligent Stepper Drive LS-143

---

Doc. # 712143001 / Rev. 1.6, 10/02/2000

## **Save Current Position as Home**

*Command value:* 0xC  
*Number of data bytes:* 0  
*Command byte:* 0x0C

### Description:

Causes the current position to be saved as the home position. This command is typically issued to a group of controllers to cause their current positions to be stored synchronously. The stored positions can then be read individually by reading the home position

## **No Operation**

*Command value:* 0xE  
*Number of data bytes:* 0  
*Command byte:* 0x0E

### Description:

Does nothing except cause a status packet with the currently defined status data to be returned.

## **Hard Reset**

*Command value:* 0xF  
*Number of data bytes:* 0  
*Command byte:* 0x0F

### Description:

Resets the control module to its power-up state. No status will be returned. Typically, this command is issued to all the modules on the network, although if the baud rate is set at the default, it is possible to reset and re-initialize the addresses of a contiguous sub-chain of modules.

Note: *Hard Reset* command sent at address 0xFF will be executed by all step Drives, regardless of their own group address.

# Logosol Intelligent Stepper Drive LS-143

Doc. # 712143001 / Rev. 1.6, 10/02/2000

## STATUS BYTE AND INPUT BYTE DEFINITIONS

### Status Byte

<u>Bit</u>	<u>Name</u>	<u>Definition</u>
0	Motor is moving	This bit is set when the motor is moving and cleared otherwise.
1	Cksum_error	Set if there was a checksum error in the command packet received.
2	Motor is on	Set if the motor power output signal is on.
3	Power sense	This bit corresponds to the state of power sense input.
4	At commanded velocity	Set if the commanded velocity is reached.
5	Velocity profile mode	Set if the motor is moving in velocity mode.
6	Position (trapezoidal) profile mode	Set if the motor is moving in trapezoidal mode.
7	Home_in_progress	Set while searching for a home position. Reset to zero once the home position has been captured.

### Input Byte

<u>Bit</u>	<u>Name</u>	<u>Definition</u>
0	IN0	Set if stop signal is activated
1	IN1	The value of input IN1
2	IN2	Reserved
3	Limit 1	The value of positive limit
4	Limit 2	The value of negative limit
5	Home	This bit is cleared when HOME input is HIGH and drive is AT FULL STEP. Set otherwise.
6	Reserved	
7	Reserved	

### I/O State Byte

<u>Bit</u>	<u>Name</u>	<u>Definition</u>
0	IN0	Set if stop signal is activated
1	IN1	The value of the input IN1
2	IN2	Reserved
3	OUT0	Reserved
4	OUT1	Reset the Stepper Drive
5	OUT2	Slow Decay mode (OUT2 OFF) or Fast (OUT2 ON)
6	OUT3	Half step mode (OUT3 OFF) or Full step (OUT3 ON)
7	OUT4	Reserved

*Note:* IN0, IN1 and IN2 in Input byte and I/O state byte are the same inputs.