

# Logosol Network I/O Node LS-773

Doc# 712773001, Rev. 1.11, 01/15/2008

## Features

- 10 general purpose digital inputs
- 3 analog inputs
- 6 open collector outputs – 1A max
- Power source output – 5A max
- All outputs are short protected
- 32-bit counter/timer with prescaler
- 20 KHz PWM mode for two of the outputs
- 12 to 32Vdc supply voltage range
- Communication speed 19.2Kbps ÷ 1.25 Mbps
- Command rate up to 1000/sec



## Description:

LS-773 is a multifunctional, I/O controller designed for a wide range of applications. Up to 31 LS-773 nodes can be controlled over a multi-drop full duplex RS-485 network. Standard RJ-45 connectors and commercially available cables are used for daisy-chaining of the modules.

## DIMENSIONAL DRAWING

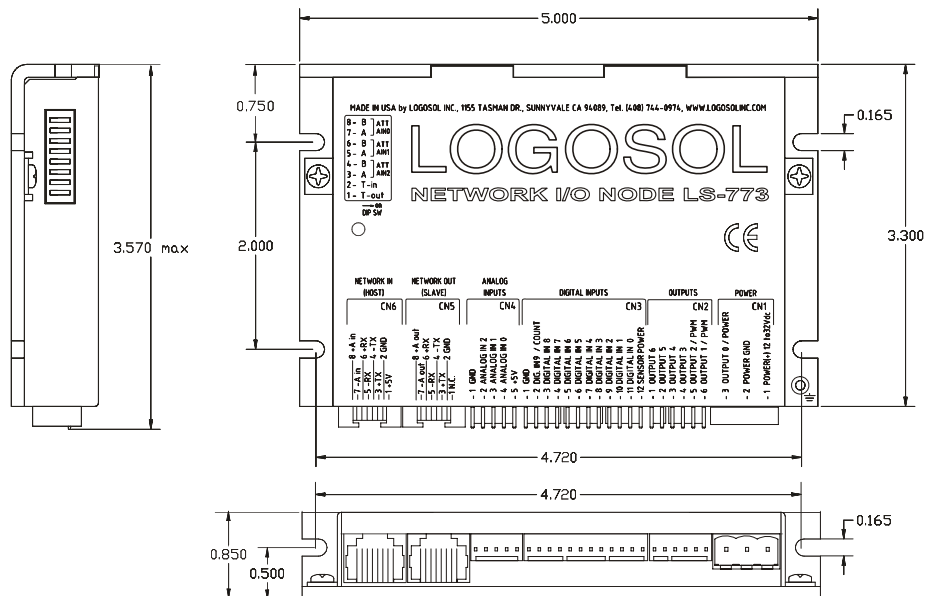

# Logosol Network I/O Node LS-773

Doc# 712773001, Rev. 1.11, 01/15/2008

## **TECHNICAL SPECIFICATIONS** rated at 25°C ambient, POWER (+)=24Vdc

|   |   |
|---|---|
| POWER SUPPLY VOLTAGE  | 12 to 32Vdc, 35Vdc Absolute Maximum   |
| DIGITAL OUTPUTS<br>OUTPUT 0/ POWER<br>OUTPUT 1 - OUTPUT 6<br>Max voltage applied to OUTPUT 1 ÷ OUTPUT 6<br>Max current load OUTPUT 1 ÷ OUTPUT 6<br>PWM switching frequency (OUTPUT 1, OUTPUT 2) | Solid-state relay – 5A<br>Open Collector with protective diode to POWER (+) for inductive loads<br>POWER (+) voltage<br>1A<br>20KHz   |
| DIGITAL INPUTS  | 3K3 pull-up resistors to POWER (+), 50% threshold   |
| ANALOG INPUTS   | 0-5V, 0-10V, 0-20V or 0-30V DIP switch selectable modes   |
| INDICATORS<br>Red LED   | Low intensity – power supply OK<br>High intensity – OUTPUT 0/ POWER=ON  |
| PROTECTION<br>Short   | Digital output to POWER (+); OUTPUT 0/ POWER to GND   |
| FIRE-SAFETY<br>Internal fuse on POWER (+)   | 10A, Quick blow   |
| THERMAL REQUIREMENTS<br>Storage temperature range<br>Operating temperature range  | -30 to +85 °C<br>0 to 45 °C   |
| MECHANICAL<br>Size<br>Weight  | L=5.00", H=3.30", D=0.85"<br>0.55 lb. (0.250 kg)  |
| MATING CONNECTORS<br>Power Supply<br>Inputs<br>Outputs<br>Analog inputs<br>Communication  | Magnum EM2565-03-VL or Phoenix contact MSTB 2.5/3-ST-5.08<br>Molex 22-01-3127 housing with 08-50-0114 pins (12 pcs.)<br>Molex 22-01-3067 housing with 08-50-0114 pins (6 pcs.)<br>Molex 22-01-3057 housing with 08-50-0114 pins (5 pcs.)<br>8 pin RJ-45 |

### **I/O NODE LAYOUT**

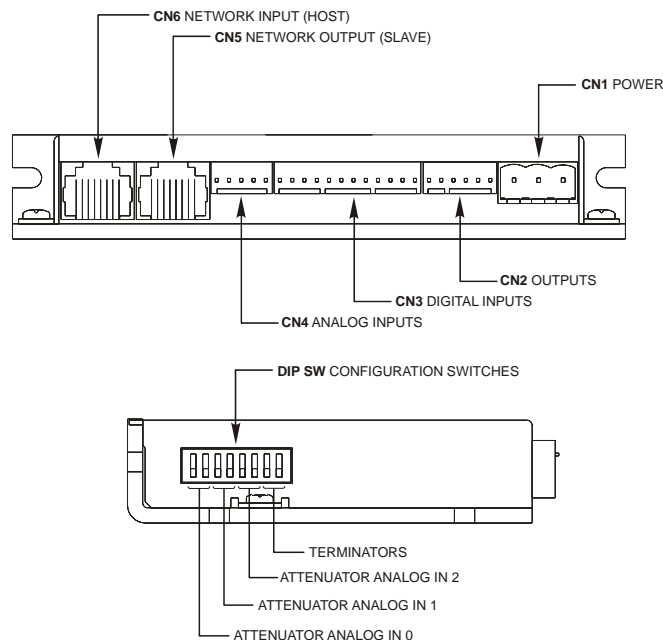

### **ORDERING GUIDE**

| PART NUMBER | MODEL     | DESCRIPTION          |
|-------------|-----------|----------------------|
| 912773001   | LS-773    | Network I/O Node     |
| 230601006   | LS-773-CN | Mating connector kit |

# Logosol Network I/O Node LS-773

Doc# 712773001, Rev. 1.11, 01/15/2008

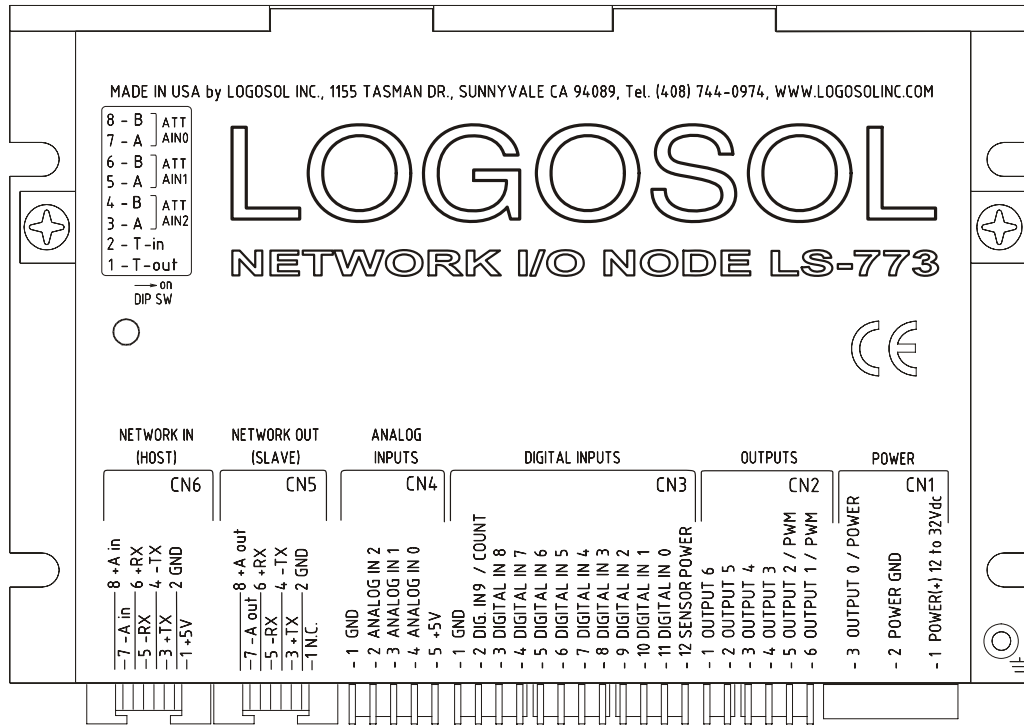

## DIP SW – DIP SWITCH

| SW | SIGNAL |            | DESCRIPTION              |
|----|--------|------------|--------------------------|
| 1  | T-out  |            | Transmit line terminator |
| 2  | T-in   |            | Receive line terminator  |
| 3  | A      | ATT<br>AN2 | ANALOG IN2 attenuator    |
| 4  | B      |            |                          |
| 5  | A      | ATT<br>AN1 | ANALOG IN1 attenuator    |
| 6  | B      |            |                          |
| 7  | A      | ATT<br>AN0 | ANALOG IN0 attenuator    |
| 8  | B      |            |                          |

## CN1 – POWER AND MOTOR CONNECTOR

| PIN | SIGNAL               | DESCRIPTION   |
|-----|----------------------|---|
| 1   | POWER(+) 12 to 32Vdc | 12 – 32Vdc power supply, positive terminal            |
| 2   | POWER GND*           | Power supply ground                                   |
| 3   | OUTPUT 0/ POWER      | Solid-state relay - 5A, with short circuit protection |

## CN2 – OUTPUTS

| PIN | SIGNAL        | DESCRIPTION                         |
|-----|---------------|-------------------------------------|
| 1   | OUTPUT 6      | Open collector output               |
| 2   | OUTPUT 5      | Open collector output               |
| 3   | OUTPUT 4      | Open collector output               |
| 4   | OUTPUT 3      | Open collector output               |
| 5   | OUTPUT 2/ PWM | Open collector output with PWM mode |
| 6   | OUTPUT 1/ PWM | Open collector output with PWM mode |

\* POWER GND and GND are electrically connected. Drive case is isolated from drive circuitry and can be grounded externally.

# Logosol Network I/O Node LS-773

Doc# 712773001, Rev. 1.11, 01/15/2008

## CN3 – DIGITAL INPUTS

| PIN | SIGNAL           | DESCRIPTION             |
|-----|------------------|-------------------------|
| 1   | GND*             | Signal ground           |
| 2   | DIG. IN 9/ COUNT | Input #9/ counter input |
| 3   | DIGITAL IN 8     | Input #8                |
| 4   | DIGITAL IN 7     | Input #7                |
| 5   | DIGITAL IN 6     | Input #6                |
| 6   | DIGITAL IN 5     | Input #5                |
| 7   | DIGITAL IN 4     | Input #4                |
| 8   | DIGITAL IN 3     | Input #3                |
| 9   | DIGITAL IN 2     | Input #2                |
| 10  | DIGITAL IN 1     | Input #1                |
| 11  | DIGITAL IN 0     | Input #0                |
| 12  | SENSOR POWER     | Wired to POWER (+)      |

## CN4 – ANALOG INPUTS

| PIN | SIGNAL      | DESCRIPTION                              |
|-----|-------------|--|
| 1   | GND*        | Signal ground                            |
| 2   | ANALOG IN 2 | Analog input 0-5V, 0-10V, 0-20V or 0-30V |
| 3   | ANALOG IN 1 | Analog input 0-5V, 0-10V, 0-20V or 0-30V |
| 4   | ANALOG IN 0 | Analog input 0-5V, 0-10V, 0-20V or 0-30V |
| 5   | +5V         | Internal power supply output             |

## CN5 – NETWORK OUT (SLAVE)

| PIN | SIGNAL | DESCRIPTION        |
|-----|--------|--------------------|
| 1   | N.C.   | Not connected      |
| 2   | GND*   | Interface ground   |
| 3   | +TX    | (+) Transmit data  |
| 4   | -TX    | (-) Transmit data  |
| 5   | -RX    | (-) Receive data   |
| 6   | +RX    | (+) Receive data   |
| 7   | -A out | (-) Address output |
| 8   | +A out | (+) Address output |

## CN6 – NETWORK IN (HOST)

| PIN | SIGNAL | DESCRIPTION                 |
|-----|--------|-----------------------------|
| 1   | +5V    | RS-232 adapter power supply |
| 2   | GND*   | Interface ground            |
| 3   | +TX    | (+) Transmit data           |
| 4   | -TX    | (-) Transmit data           |
| 5   | -RX    | (-) Receive data            |
| 6   | +RX    | (+) Receive data            |
| 7   | -A in  | (-) Address input           |
| 8   | +A in  | (+) Address input           |

\* POWER GND and GND are electrically connected. Drive case is isolated from drive circuitry and can be grounded externally.

# Logosol Network I/O Node LS-773

Doc# 712773001, Rev. 1.11, 01/15/2008

## SAMPLE APLICATION

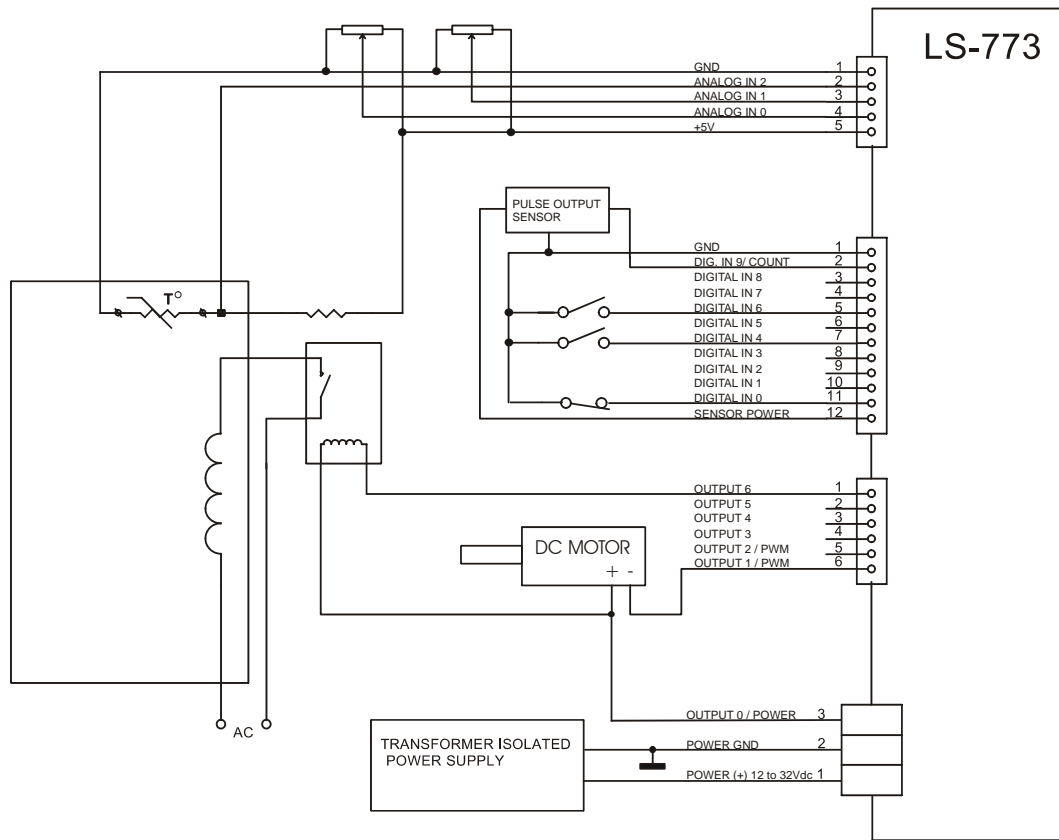

## LOGOSOL LS-773 QUICK START GUIDE

### Hardware Setup

1. Connect power supply (12 to 32Vdc) to LS-773.
2. Connect your I/O devices to LS-773 inputs and outputs.
3. Connect RS-232 adapter and RJ-45 network cable between LS-773 and your host computer.

### Software Installation

#### 1. Installation and using Logosol Distributed Control Network Utility

##### A. Installation

1. Insert the Logosol Distributed Control Network Utility installation disk into the floppy drive.
2. Select Run from the Windows 95/98/NT/XP Start menu.
3. Type a:\dcnsetup and then click OK (a: represents the drive letter).
4. The installation wizard will guide you through the setup process.

# Logosol Network I/O Node LS-773

Doc# 712773001, Rev. 1.11, 01/15/2008

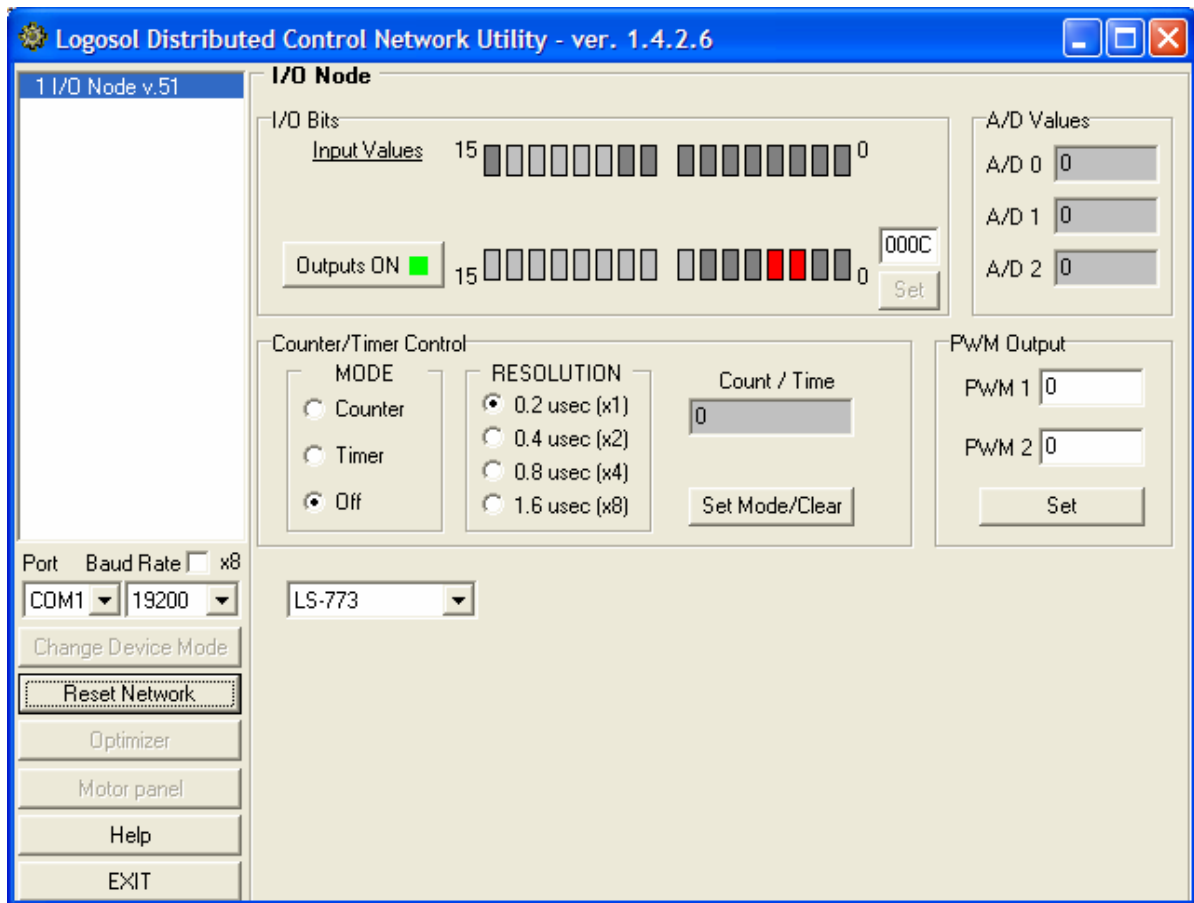

## B. Initial Connection to the Host

1. Turn on the power supply.
2. Run the Logosol Distributed Control Network Utility.
3. Choose the proper COM port
4. You will see the IO node specific screen. More information about using LDCN utility is available in LDCN Help.

## 2. Installation and using Logosol Motion Control Center

### A. Installation

1. Insert the Logosol Motion Control Center installation disk into the floppy drive.
2. Select Run from the Windows 95/98/NT Start menu.
3. Type a:\mccsetup and then click OK (a: represents the drive letter).
4. The installation wizard will guide you through the setup process.

### B. Initial Connection to the Host

1. Turn on the power supply.
2. Run the Logosol Motion Control Center software.
3. From the **Connection** menu select **Terminal**. This will open a terminal window. From the **Target** pull-down list select either RS-485-COM1 or RS-485-COM2 corresponding to the one used to communicate with LS-173. Press the Return key to verify that the connection is established and the command prompt (>) appears on the terminal window.

# Logosol Network I/O Node LS-773

Doc# 712773001, Rev. 1.11, 01/15/2008

4. Type **INI** at the command prompt followed by Return to initialize the controller. It may take few seconds to complete the process.
5. Type **XST** to check the status of LS-773 I/O Node and refer to the following MCL Terminal Interpreter Command Set for executing various I/O commands.

## MCL TERMINAL INTERPRETER COMMAND SET

The following commands are available from the Terminal prompt:

**XST** – displays status information:

- 1) **"XST"** displays status info for all modules on the network;
- 2) **"XST A1"** displays status info for module A1.

Status information for module LS-773 includes:

- 1) Address
- 2) Status byte
- 3) Inputs bytes
- 4) Analog In0
- 5) Analog In1
- 6) Analog In2
- 7) Counter value
- 8) Device ID
- 9) Version number

**PWM** – returns or sets PWM1 or PWM2 outputs in range 0÷255:

- 1) **"PWM"** returns all PWMs for all modules on the network\*;
- 2) **"PWM A1X2"** returns PWM2 value of module A1\*;
- 3) **"PWM A1X1=Y"** sets PWM1 of module A1 with output value Y=0÷255\*\*;
- 4) **"PWM A1X2=Y"** sets PWM2 of module A1 with output value Y=0÷255\*\*.

\*Note: Output 1 and Output 2 can be used as normal or as PWM outputs. If the output has been set to be PWM output then the command **PWM** (as shown in examples 1 and 2) will return its value.

\*\*Note: PWM value of Y= 255 corresponds to min and Y=0 to max output signal.

**VER** – returns MCL interpreter version.

**IN** – returns the state of the inputs.

- 1) **"IN"** returns the state of all 10 inputs of all modules;
- 2) **"IN A1X5"** returns the state of input 5 of module A1.

**OUT** – returns or sets the state of the outputs.

- 1) **"OUT"** returns the state of all 7 outputs of all modules;
- 2) **"OUT A1X1"** returns the state of output 1 of module A1;
- 3) **"OUT A1X3=0"** sets to 0 the output 3 of module A1;
- 4) **"OUT A1X1=1"** sets to 1 the output 1 of module A1.

**INI** – resets the network and assigns individual addresses if necessary.

**SCM** – returns or sets counter mode:

- 1) **"SCM"** returns information for counter mode for all modules;
- 2) **"SCM A1X1"** returns information for counter mode for module A1;

# Logosol Network I/O Node LS-773

---

Doc# 712773001, Rev. 1.11, 01/15/2008

- 3) **"SCM A1X1=D"** disables counter mode for module A1;
- 4) **"SCM A1X1=E 2"** sets counter mode for module A1 with prescaler 2\*.

\*Note: The prescaler values 1, 2, 4 or 8 define counter ratio 1:1, 2:1, 4:1 or 8:1.

**CNT** – returns the counter content:

- 1) **"CNT"** returns counters content of all modules on the network;
- 2) **"CNT A1X1"** returns counter content of module A1.

**ADC** – returns the value of the analog inputs:

- 1) **"ADC"** returns the values of all analog inputs of all modules;
- 2) **"ADC A1X0"** returns the value of the analog input 0 of module A1.

**HEX** – hex command mode – sends a low-level command written in hexadecimal format. For more information about command format refer to "Command Description" section in this document. Start byte (AA) and checksum byte are generated by the MCL interpreter:

**"HEX 01 13 04"** - sends "Read Status" command (code 0x13) for module #1 with data byte = 0x04.

**BDR** – sets different baud rate (19200, 57600 and 115200)

**"BDR 115200"** - sets baud rate to 115.2 Kbps.

Note: baud rate is set to 19.2 Kbps after power-up.

**HIS** – shows the history of the last used commands, their hexadecimal codes and the returned status bytes.

**EXE** – executes a text file containing sequence of MCL commands.

**"EXE control.dat"** - executes the command sequence from "control.dat" file in current directory.

**NET** – displays number and types of all modules on the network and their addresses.

# Logosol Network I/O Node LS-773

Doc# 712773001, Rev. 1.11, 01/15/2008

## LS-773 ARCHITECTURE

### Overview

LS-773 - Network I/O Node provides the following I/O capabilities:

Ten digital input lines.

Power source output.

Six open collector outputs (two of them may be used as PWM outputs)

Three 8-bit analog input channels.

One 32-bit counter/timer.

RS-485 serial interface allows up to 31 modules LS-773 to be controlled from a single serial port.

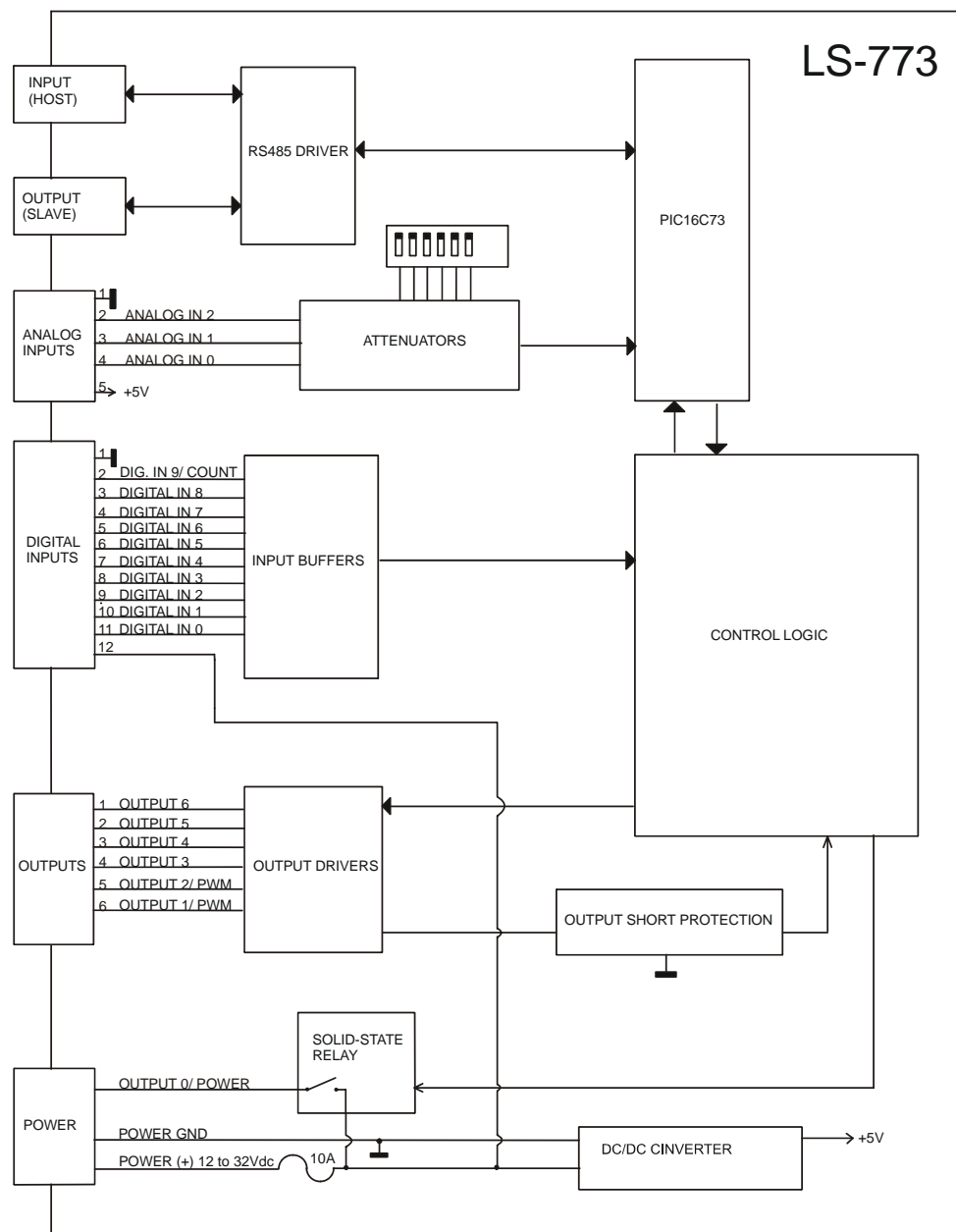

Functional Diagram

# Logosol Network I/O Node LS-773

Doc# 712773001, Rev. 1.11, 01/15/2008

## Serial Command Interface

The serial communication with the LS-773 drives adheres to a full-duplex (4 wire) 8 bit asynchronous protocol with one start bit, followed by 8 data bits (lsb first), followed by a single stop bit.

The communication protocol also supports a full-duplex multi-drop RS-485 interface which allows multiple LS-773 Network I/O Nodes to be controlled over a single RS-485 port. In this case, the host sends commands over its RS-485 transmit line and receives all status data back over the shared RS-485 receive line. The command protocol is a strict master/slave protocol in which the host master sends a command packet over the command line to a specific LS-773 slave. The Node sends back a status packet. Typically, the host does not send another command until a status packet has been received to insure that it does not overwrite any previous command data still in use.

Each command packet consists of the following:

- Header byte (0xAA)*
- Address byte - individual or group (0x00 - 0xFF)*
- Command byte*
- 0 - 15 data bytes*
- Checksum byte*

The command byte is divided into upper and lower nibbles: the lower nibble is the command value; the upper nibble is the number of additional data bytes, which will follow the command byte. The checksum byte is 8-bit sum of the address byte, the command byte and the data bytes. The number of data bytes depends on the particular command chosen. After a command is issued, the corresponding node will send back a status packet consisting of:

- Status byte*
- Optional bytes of status data*
- Checksum byte*

The Status Byte contains basic status data about the LS-773, including a checksum error flag for the command just received. The number and the meaning of Optional Status Data Bytes are programmable by the user and may include any, none or all of data available from the module. The checksum byte is the 8-bit sum of the status byte and the additional optional status data bytes. All 16-bit and 32-bit data is sending with the least significant byte first.

## Addressing

Rather than using hard-wired or switch-selected address of each LS-773 node, the host dynamically sets the address of each LS-773 with the aid of the daisy-chained "A in" and "A out" lines. This allows additional LS-773 controllers to be added to an RS-485 network with no hardware changes. On Power-up, "A in" of the first LS-773 is pulled low, its communication is enabled and the default address is 0x00. When the *Set Address* command is issued to give this LS-773 new unique address, it will lower its "A out" line. Connecting "A out" to the "A in" of the next node on the network will enable its communication at default address of 0x00. Repeating this procedure allows a variable number of controllers present to be given an unique addresses.

## Group Addresses

In addition to the individual address, each node has a secondary group address. Several LS-773 controllers may share a common group address. This address is useful for sending commands, which must be performed simultaneously by a number of nodes (e.g. *Set Baud Rate*, etc.). When a LS-773 receives a command sent to its group address, it will execute the command but not send back a status packet. This prevents data collisions on the shared

# Logosol Network I/O Node LS-773

Doc# 712773001, Rev. 1.11, 01/15/2008

response line. When programming group addresses, however, the host can specify that one member of the group is the "group leader". The group leader will send back a status packet just like it would for a command sent to its individual address. The group address is programmed at the same time as the unique individual address using the *Set Address* command.

## Changing Communications Rates

The default baud rate after Power-up is 19.2 Kbps. Baud rates up to 1.25 Mbps may be used. After communication has been established with all nodes on a single network, the baud rate may be changed to a higher value with the *Set Baud Rate* command.

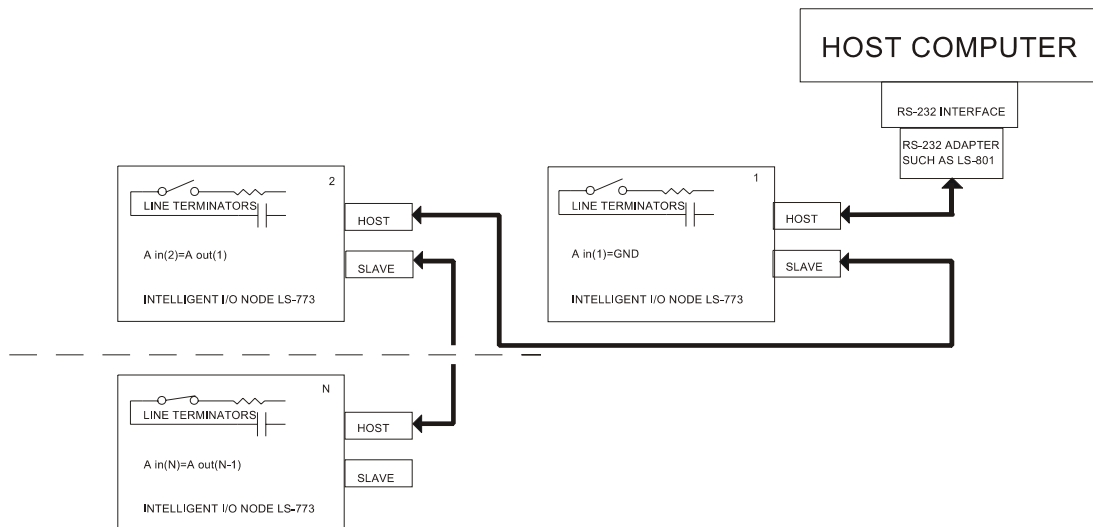

Multiple Controller Configuration

## Digital Outputs

LS-773 features 7 outputs - OUTPUT 0 to OUTPUT 6.

OUTPUT 0/ POWER is designed with solid-state relay and may be used for powering of user devices or as a general purpose output capable to source 5A. OUTPUT 0/ POWER is protected against short to GND.

OUTPUT 1 to OUTPUT 6 are open collector outputs capable to sink 1A and are equipped with protective diodes for inductive loads. Outputs are protected against short to POWER (+).

OUTPUT 1 and OUTPUT 2 may be used as general-purpose outputs or as PWM outputs. To use OUTPUT 1 or OUTPUT 2 as simple outputs set PWM1 or PWM2 to 0. If OUTPUT 1, or OUTPUT 2 are set to 1 then:

- PWM=255 - 0% PWM (output off);
- PWM=128 - 50% PWM;
- PWM=0 - 100% PWM (output on).

If one or more active open collector output are shorted to POWER (+), all outputs will be turned off and cannot be controlled while shorted. The normal operation, after short, is restored by the next setting of outputs.

# Logosol Network I/O Node LS-773

Doc# 712773001, Rev. 1.11, 01/15/2008

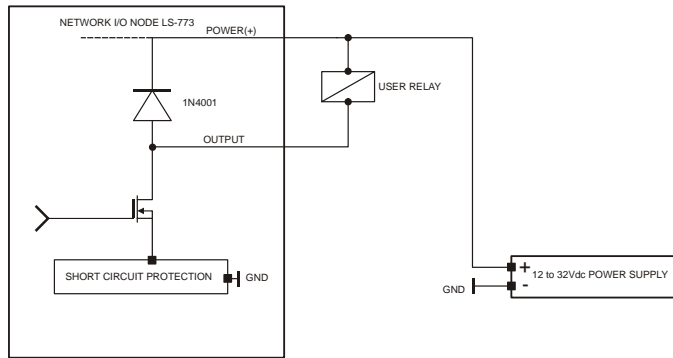

Digital Outputs

## Digital Outputs

| Output | Bit 7 | Bit 6    | Bit 5    | Bit 4    | Bit 3    | Bit 2           | Bit 1           | Bit 0             |
|--------|-------|----------|----------|----------|----------|-----------------|-----------------|-------------------|
| Byte 0 | X     | OUTPUT 6 | OUTPUT 5 | OUTPUT 4 | OUTPUT 3 | OUTPUT 2<br>PWM | OUTPUT 1<br>PWM | OUTPUT 0<br>POWER |
| Byte 1 | X     | X        | X        | X        | X        | X               | X               | X                 |

## Digital Inputs

LS-773 has 10 general-purpose digital inputs - DIGITAL IN 0 to DIGITAL IN 9. To activate an input the corresponding sensor must be able to sink 8mA/24V. All inputs are equipped with pull-up resistors to POWER (+).

DIGITAL IN 9/ COUNT is an input with two functions: digital input and counter input. For counter/timer mode refer to *Set Timer Mode* command in the Command Description section of this document.

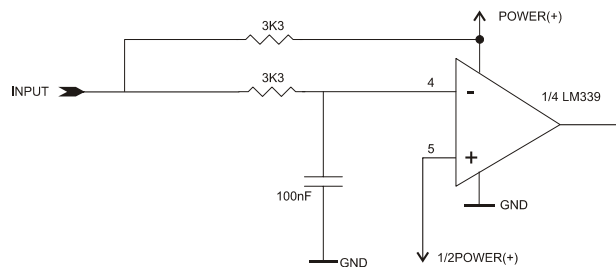

Digital Inputs

## Digital Inputs\*

| Input  | Bit 7   | Bit 6   | Bit 5   | Bit 4   | Bit 3   | Bit 2   | Bit 1   | Bit 0   |
|--------|---------|---------|---------|---------|---------|---------|---------|---------|
| Byte 0 | INPUT 7 | INPUT 6 | INPUT 5 | INPUT 4 | INPUT 3 | INPUT 2 | INPUT 1 | INPUT 0 |
| Byte 1 | OUT_SH  | X       | X       | X       | X       | X       | INPUT 9 | INPUT 8 |

OUT\_SH is an output short indicator.

In case of OUTPUT 1 to OUTPUT 6 short to POWER(+), OUT\_SH will be set to 1. To clear OUT\_SH bit set OUTPUT 1 to OUTPUT 6 to 0.

During the normal operation OUT\_SH is 0.

\* INPUT  $x=1$  when DIGITAL IN  $x$  is in active low level.

# Logosol Network I/O Node LS-773

Doc# 712773001, Rev. 1.11, 01/15/2008

## Analog Inputs

LS-773 has three 8 bit analog inputs. The input range may be set using DIP Switch 3-8 as shown below:

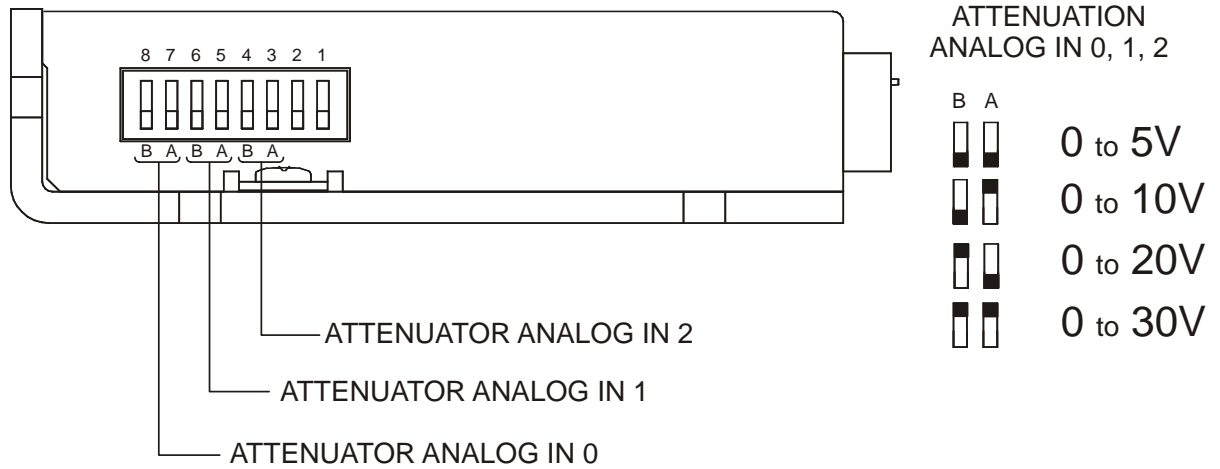

# Logosol Network I/O Node LS-773

Doc# 712773001, Rev. 1.11, 01/15/2008

## COMMAND SPECIFICATION

The following section describes in detail the commands available for the LS-773.

| Command          | CMD Code | # Data bytes | Description  |
|------------------|----------|--------------|--|
| ---              | 0X0      | 0            | Not used   |
| Set Address      | 0x1      | 2            | Sets the individual and group addresses  |
| Define Status    | 0x2      | 1            | Defines which data should be sent in every status packet   |
| Read Status      | 0x3      | 1            | Causes particular status data to be returned just once   |
| Set PWM          | 0x4      | 2            | Immediately sets the PWM output values   |
| Synch Output     | 0x5      | 0            | Outputs previously stored output bits and PWM output values  |
| Set Outputs      | 0x6      | 2            | Immediately sets the states of the output bits   |
| Set Synch Output | 0x7      | 4            | Stores output bit values and PWM values to be synchronously set with the <i>Synch Output</i> command |
| Set Timer Mode   | 0x8      | 1            | Sets mode of the counter/timer and its prescaler   |
| ---              | 0x9      | 0            | Not used   |
| Set Baud Rate    | 0xA      | 1            | Sets the baud rate (group command only)  |
| ---              | 0xB      | 0            | Not used   |
| Synch Input      | 0xC      | 0            | Synchronously stores the input bit values and the counter/timer value                                |
| ---              | 0xD      | 0            | Not used   |
| Nop              | 0xE      | 0            | Simply causes the defined status data to be returned   |
| Hard reset       | 0xF      | 0            | Resets the controller to its power-up state.   |

## LS-773 Command Description

### Set Address

Command value: 0x1

Number of data bytes: 2

Command byte: **0x21**

Data bytes:

1. Individual address: 0x00-0x7F (initial value 0x00)
2. Group Address: 0x80-0xFF (initial value 0xFF)

### Description:

Sets the individual address and group address. Group addresses are always interpreted as being between 0x80 and 0xFF. If a LS-773 is to be a group leader, clear bit 7 of the desired group address in the second data byte. LS-773 will automatically set bit 7 internally after flagging itself as a group leader. (If bit 7 of the second data byte is set, the module will be by default a group member.) The first time this command is issued after power-up or reset, it will also enable communications for the next module on the network chain by lowering the it's "A out" signal.

# Logosol Network I/O Node LS-773

Doc# 712773001, Rev. 1.11, 01/15/2008

## Define Status

Command value: 0x2

Number of data bytes: 1

Command byte: **0x12**

Data bytes:

1. Status items: (default: 0x00)

Bit 0: send Input Byte 0 and Byte 1 (2 bytes)

1: send ANALOG IN 0 value (1 byte)

2: send ANALOG IN 1 value (1 byte)

3: send ANALOG IN 2 value (1 byte)

4: send counter/timer value (4 bytes, least significant first)

5: send device ID, version number (2 bytes)

(LS-773 device ID = 2, version number = 50)

6: send input bit values captured with the Synch Input command (2 bytes)

7: send counter/timer value captured with the Synch Input command (4 bytes)

### Description:

Defines what additional data will be sent in the status packet along with the status byte. Setting bits in the data byte will cause the corresponding additional data to be included in the status packet. The status data will always be sent in the order listed. For example if bits 0 and 3 are set, all subsequent status packets will consist of the status byte followed by two bytes of input bit data, followed by the ANALOG IN 2 input byte, followed by the checksum. The status packet returned in response to this command will include the additional data bytes specified. On power-up or reset, the default status packet will include only the status byte and the checksum byte.

## Read Status

Command value: 0x3

Number of data bytes: 1

Command byte: **0x13**

Data bytes:

1. Status items: (default: 0x00)

Bit 0: send Input Byte 0 and Byte 1 (2 bytes)

1: send ANALOG IN 0 value (1 byte)

2: send ANALOG IN 1 value (1 byte)

3: send ANALOG IN 2 value (1 byte)

4: send counter/timer value (4 bytes, least significant first)

5: send device ID, version number (2 bytes)

(LS-773 device ID = 2, version number = 50)

6: send input bit values captured with the Synch Input command (2 bytes)

7: send counter/timer value captured with the Synch Input command (4 bytes)

### Description:

This is a non-permanent version of the *Define Status* command. The status packet returned in response to this command will incorporate the data bytes specified, but subsequent status packets will include only the data bytes previously specified with the *Define Status* command.

# Logosol Network I/O Node LS-773

Doc# 712773001, Rev. 1.11, 01/15/2008

## Set PWM

Command value: 0x4  
Number of data bytes: 2  
Command byte: **0x24**  
Data bytes:  
1. PWM 1 output value (255 - 0)  
2. PWM 2 output value (255 - 0)

### Description:

Immediately set the two PWM output values. To use OUTPUT 1, 2 in PWM mode set output byte bits 1 and 2 (*Set Output* command) to 1. A value of 255 will turn off the PWM output; a value of 0 will turn it on with a 100% duty cycle.

## Synch Output

Command value: 0x5  
Number of data bytes: 0  
Command byte: **0x05**  
Data bytes:  
None

### Description:

Synchronously set the output bit values and PWM values previously stored with the *Set Synch Output* command.

## Set Output

Command value: 0x6  
Number of data bytes: 2  
Command byte: **0x26**  
Data bytes:  
1. Output Byte 0  
2. Output Byte 1

### Description:

Immediately sets the values for the output bits.

## Set Synch Output

Command value: 0x7  
Number of data bytes: 4  
Command byte: **0x47**  
Data bytes:  
1. Bit values for Output bits 0-6 (bit 7 is ignored)  
2. Set this byte to 0x00  
3. PWM 1 output value (255-0)  
4. PWM 2 output value (255-0)

### Description:

Stores output bit values and PWM values in internal registers to be set synchronously with the *Synch Output* command.

# Logosol Network I/O Node LS-773

Doc# 712773001, Rev. 1.11, 01/15/2008

## Set Timer Mode

Command value: 0x8  
Number of data bytes: 1  
Command byte: 0x18  
Data bytes:

1. Timer mode configuration byte

Bit 0: 0 = Counter/timer disabled, 1 = Counter/timer enabled

Bit 1: 0 = Select timer mode, 1 = Select counter mode

Bits 5,4: 00 = No prescaler (count every event)

01 = 2:1 prescaler (every other event counted)

10 = 4:1 prescaler (every 4<sup>th</sup> event counted)

11 = 8:1 prescaler (every 8<sup>th</sup> event counted)

Bits 2,3,6,7: are not used

### Description:

Sets the operating mode of the counter/timer. In counter mode, each active (high to low) transition of DIGITAL IN 9/ COUNT will be counted. In timer mode, the counter counts the LS-773's 5.0 MHz internal clock. The prescaler applies to both the counter and the timer modes.

## Set Baud Rate

Command value: 0xA  
Number of data bytes: 1  
Command byte: 0x1A  
Data bytes:

1. Baud rate divisor, BRD

sample values:

|         |            |
|---------|------------|
| 9600    | BRD = 0x81 |
| 19200   | BRD = 0x3F |
| 57600   | BRD = 0x14 |
| 115200  | BRD = 0x0A |
| 125000  | BRD = 0x27 |
| 312500  | BRD = 0x0F |
| 625000  | BRD = 0x07 |
| 1250000 | BRD = 0x03 |

### Description:

Sets the communications baud rate. All control modules on the network must have their baud rates changed at the same time, therefore this command should only be issued to a group including all of the modules on the network. A status packet returned from this command would be at the new baud rate, so typically, there should be no group leader when this command is issued. (Note that the host's baud rate must also be changed for subsequent communication.)

## Synch Input

Command value: 0xC  
Number of data bytes: 0  
Command byte: 0x0C  
Data bytes:  
None

### Description:

Causes the current Input bit values and the counter/timer value to be synchronously stored in the LS-773's internal registers. These values can be read using the *Read Status* or the *Define Status* commands.

# Logosol Network I/O Node LS-773

---

Doc# 712773001, Rev. 1.11, 01/15/2008

## No Operation

*Command value:* 0xE  
*Number of data bytes:* 0  
*Command byte:* 0x0E

### Description:

Does nothing except that causes a status packet with the currently defined status data to be returned.

## Hard Reset

*Command value:* 0xF  
*Number of data bytes:* 0  
*Command byte:* 0x0F

### Description:

Resets modules to their power-up state. No status will be returned. Typically, this command is issued to all modules on the network, although if the baud rate is set to the default value, it is possible to reset and re-initialize the addresses of a contiguous sub-chain of modules.

## Status Byte

The first byte of each status packet is the status byte. The LS-773 has only one bit defined: *if bit 1 of the Status Byte is set*, the LS-773 detected a *checksum error* in most recently command packet. Bits 0, 2, 3, 4, 5, 6 and 7 are undefined and can be ignored.

# Logosol Network I/O Node LS-773

Doc# 712773001, Rev. 1.11, 01/15/2008

## Initializing Procedure and Programming Examples for LS-773

To ensure a proper operation of LS-773 nodes connected to the network, the addresses for all connected units must be set.

### Understanding the Serial Communication with LS-773

The Serial Communication with LS-773 is strictly master-slave and includes repeatedly two elements:

- Sending a command to the specified node's address;
- Receiving answer to the sent command – Status Byte(s).

**Note:** During the communication all bytes are sent with LSB first.

### Commands

There are 12 commands controlling LS-773 nodes (refer to LS -773 Command Description). Each command as shown in the following two tables includes header, address, command, data bytes and one checksum byte. Checksum does not include the header byte.

#### Structure of *Read Status* command

| Byte 1 | Byte 2                           | Byte 3                                 |                               | Byte 4    | Byte 5                                       |
|--------|----------------------------------|--|-------------------------------|-----------|--|
| Header | Address<br>(Individual or Group) | Command Code                           |                               | Data Byte | CheckSum =<br>Byte 2 + Byte 3 +<br>Data Byte |
|        |                                  | High 4 bits<br>number of data<br>bytes | Low 4 bits<br>command<br>code |           |  |
| AA     | 01                               | 1                                      | 3                             | 01        | 15   |

#### Examples

| Cmd. Bytes       | Byte 1 | Byte 2  | Byte 3    | Byte 4 – N   | Byte N+1 |
|------------------|--------|---------|-----------|--------------|----------|
| Command          | Header | Address | Cmd. Code | Data Byte(s) | Checksum |
| No operation     | AA     | 01      | 0 E       |              | 0F       |
| Define Status    | AA     | 05      | 1 2       | 05           | 1C       |
| Set Address      | AA     | 01      | 2 1       | 07 FF        | 28       |
| Set Synch Output | AA     | 01      | 4 7       | 07 01 80 00  | D0       |

### Status Data

The structure of the returned status information depends on *Define Status* or *Read Status* commands (refer to LS-773 Command Description). By default only the Status byte and Checksum are returned to the host. Normally the returned Status Byte is 00h.

#### Examples

| Byte 1      | Optional Bytes 0-16   | CheckSum                           |
|-------------|---|------------------------------------|
| Status Byte | Additional Status Bytes as inputs, A/Ds, counter / timer, version, etc. | CheckSum = Byte 1 + Optional Bytes |
| 00          | no additional status bytes requested                                    | 00                                 |
| 00          | 01 23 05 10 – four additional status bytes                              | 39                                 |

# Logosol Network I/O Node LS-773

Doc# 712773001, Rev. 1.11, 01/15/2008

## Addressing

Each node on the daisy-chained network has two addresses:

- Individual - for individual control of each node. It is from 01h to 7Fh.
- Group - for simultaneous control of all group members by sending a single command to their group address. It is between of 80h to FFh.

Both individual and group addresses have to be set during the initialization process.

The group may have Group leader responsible to send status data. Its address is:

Group leader address = Group address - 80h.

If there is no group leader - no status data will be send after a group command.

*Set Baud Rate* command must be sent only as a group command with no group leader, otherwise communication problems may occur.

## Set Address Command:

Next table presents the structure of *Set Address* command. The preset address 00h is set by the firmware after power-up.

### Example of *Set Address* command

| Byte 1 | Byte 2         | Byte 3       | Byte 4             | Byte 5        | Byte 6   |
|--------|----------------|--------------|--------------------|---------------|----------|
| Header | Preset Address | Command code | Individual Address | Group Address | Checksum |
| AA     | 00             | 21           | 01                 | FF            | 21       |

## Setting the Addresses

After power-up and *Hard Reset* command all nodes have their address set to 00h and only the first node (starting from the host) has its communication enabled. Consecutive *Set Address* commands are sent to address 00h until all nodes are addressed. This procedure can be executed once after *Hard Reset*. The table below shows the steps to address 3-nodes network.

### Example of sequential addressing for three LS-773 nodes

| step | Command                | Set address Hexadecimal Code | Node 1                                  |               | Node 2                                   |               | Node 3                                   |               |
|------|------------------------|------------------------------|---|---------------|--|---------------|--|---------------|
|      |                        |                              | Individual address                      | Group address | Individual address                       | Group address | Individual address                       | Group address |
| 0    | Power-up               |                              |   |               |  |               |  |               |
| 1    | Hard Reset             | AA FF 0F 0E                  | address=00 communication <i>enabled</i> |               | address=00 communication <i>disabled</i> |               | address=00 communication <i>disabled</i> |               |
| 2    | Set Address Node1 = 01 | AA 00 21 01 FF 21            | 01                                      | FF            | address=00 communication <i>enabled</i>  |               | address=00 communication <i>disabled</i> |               |
| 3    | Set Address Node2 = 02 | AA 00 21 02 FF 22            | 01                                      | FF            | 02                                       | FF            | address=00 communication <i>enabled</i>  |               |
| 4    | Set Address Node3 = 03 | AA 00 21 03 FF 23            | 01                                      | FF            | 02                                       | FF            | 03                                       | FF            |

**Note:** Before start addressing *Hard Reset* command must be issued.

# Logosol Network I/O Node LS-773

Doc# 712773001, Rev. 1.11, 01/15/2008

The flowchart shows the addressing procedure of N drives network. There is no group leader and the group address is FF.

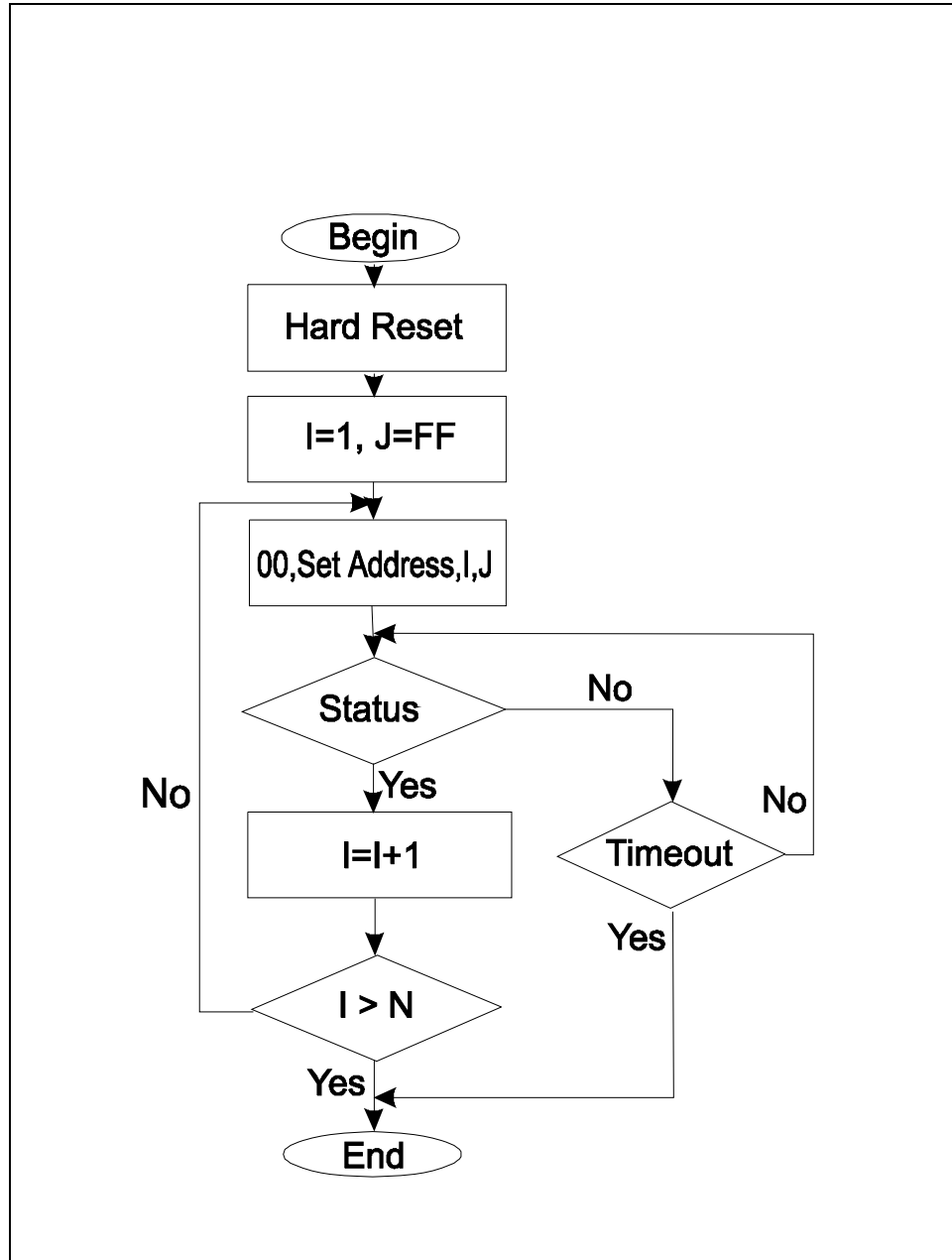

*I* - Individual Address; *J* - Group Address = FF;  
*Status* - Status Data sent to the Host; *Timeout* - Greater than one servo circle.

# Logosol Network I/O Node LS-773

Doc# 712773001, Rev. 1.11, 01/15/2008

## Examples of Managing Two LS-773 Nodes

- # 1 – Resets all nodes with group command.
- # 2 and # 3 - Sets the addresses of node1 and 2.
- # 4, # 5 - Reads the inputs of node 1, node 2.
- # 6, # 7 - Reads analog inputs of node 1, node 2.
- # 8, # 9 - Sets the outputs of node 1, node 2.
- # 10 and # 11 - Sets PWM values of node 1.
- # 12 and # 13 - Sets PWM values of node 2.
- # 14 and # 15 - Sets timer mode for node 1 and read four timer's bytes.
- # 16 and # 17 - Sets counter mode for node 2 and read four counter's bytes.

## Examples

| #  | Hexadecimal code of command | Comments  |
|----|-----------------------------|---|
| 1  | AA FF 0F 0E                 | <i>Hard Reset</i>   |
| 2  | AA 00 21 01 FF 21           | Sets address 01h for node 1. Group address is FFh.  |
| 3  | AA 00 21 02 FF 22           | Sets address 02h for node 2. Group address is FFh.  |
| 4  | AA 01 13 01 15              | Reads inputs of node 1.<br>Use <i>Read Status</i> command. Set Command Byte to 01h to read the inputs.  |
| 5  | AA 02 13 01 16              | Reads inputs of node 2.<br>Use <i>Read Status</i> command. Set Command Byte to 01h to read the inputs.  |
| 6  | AA 01 13 0E 22              | Reads analog inputs' values of node 1.<br>Use <i>Read Status</i> command. Set Command Byte to 0Eh. When Command Bits 1, 2 and 3 are set to 1 the analog inputs' values are requested. |
| 7  | AA 02 13 0E 23              | Reads analog inputs' values of node 2.<br>Use <i>Read Status</i> command. Set Command Byte to 0Eh.  |
| 8  | AA 01 26 07 00 2E           | Sets outputs 0, 1 and 2 of node 1. Second output byte is 00h.   |
| 9  | AA 02 26 33 00 5B           | Sets outputs 0, 1, 4 and 5 of node 2. Second output byte is 00h.  |
| 10 | AA 01 26 06 00 2D           | Sets outputs 1 and 2 of node 1, before to set PWM.  |
| 11 | AA 01 24 80 56 FB           | Sets PWM for node 1 – PWM1=80h, PWM2=56h.   |
| 12 | AA 02 26 06 00 2E           | Sets outputs 1 and 2 of node 2, before to set PWM.  |
| 13 | AA 02 24 00 FF 25           | Sets PWM for node 2. – PWM1=00h, PWM2=FFh.  |
| 14 | AA 01 18 01 1A              | Sets timer mode for node 1.<br>Use <i>Set Timer Mode</i> command. Command Bit 0 is set to 1. Command Bits 5 and 4 are set to 0 (no prescaler).  |
| 15 | AA 01 13 10 24              | Reads timer bytes from node 1.<br>Use <i>Read Status</i> command with Command Byte to 10h.  |
| 16 | AA 02 18 03 1D              | Sets counter mode for node 2.<br>Use <i>Set Timer Mode</i> command for node 2. Command Bits 0 and 1 are set to 1. Command Bits 5 and 4 are set to 0 (count every event).              |
| 17 | AA 02 13 10 25              | Reads counter bytes from node 2.<br>Use <i>Read Status</i> command. Set Command Byte to 10h.  |