

LOGOSOL PREALIGNERS

Features

- ❑ Innovative, high-performance, class 1 compatible.
- ❑ Unique all-in-one design. Eliminates external controller and interconnecting cables while maintaining drop-in compatibility.
- ❑ Scanning electronics, motion controller and power supply elements included within an industry standard footprint.
- ❑ Driven by ultra low inertia brushless motor for smooth, instant response.
- ❑ Advanced scanning electronics capable of detecting transparent, semi-transparent and opaque objects without mechanical repositioning between different wafer sizes.
- ❑ Seamlessly interfacing with a wafer handling robots supporting all wafer sizes from 50 mm to 300 mm and the respective sizes of square substrates.
- ❑ Motion control software featuring a comprehensive set of commonly used commands to maintain compatibility while integrating the prealigners in variety of semiconductor platforms.
- ❑ Typical aligning cycle time of less than 4 seconds facilitates achieving maximum system throughput.
- ❑ Available as 3-axes stand alone vacuum retention or edge handling configurations and as single axis devices working in conjunction with wafer handling robot and Logosol control software.

Basic configurations



Three axis, 3"-12" wafers



Single axis, 3"-12" wafers



Three axis, 3"- 8" wafers



Edge handling, 8" wafers

		Prealigner type												
		26-3	38-3	58-3	812-3	312-3	25-1	58-1	812-1	312-1	6EH	8EH	12EH	
Servo Axes		3	3	3	3	3	1	1	1	1	3	3	3	
Vac. Chuck		√	√	√	√	√	√	√	√	-	-	-		
Edge handling		-	-	-	-	-	-	-	-	√	√	√		
Wafer diameter [mm]	50 mm	√	-	-	-	-	√	-	-	-	-	-		
	75 mm	√	√	-	-	√	√	-	-	√	-	-		
	100 mm	√	√	-	-	√	√	-	-	√	-	-		
	125 mm	√	√	√	-	√	√	√	-	√	-	-		
	150 mm	-	√	√	-	√	-	√	-	√	√	-		
	200 mm	-	√	√	√	√	-	√	√	√	-	√	-	
	300 mm	-	-	-	√	√	-	-	√	√	-	-	√	
Square substrates		√	√	√	√	√	√	√	√	√	-	-	-	
Wafer opacity	Opaque	√	√	√	√	√	√	√	√	√	√	√	√	
	Trans-parent	√	√	√	√	√	√	√	√	√	√	√	√	
	Semi-Transp.	√	√	√	√	√	√	√	√	√	√	√	√	
Accuracy	Center offset [μm]	±25	±25	±25	±25	±25	±50	±50	±50	±50	±25	±25	±25	
	Notch/Flat angular	10K Enc	±0.04°	±0.04°	±0.04°	±0.04°	±0.04°	±0.06°	±0.06°	±0.06°	±0.06°	±0.04°	±0.04°	±0.04°
		24K Enc	±0.02°	±0.02°	±0.02°	±0.02°	±0.02°	±0.04°	±0.04°	±0.04°	±0.04°	±0.02°	±0.02°	±0.02°
Host	RS232	Standard					Robot daisy chained				Standard			
	Ethernet	Optional									Optional			
Initial Wafer offset [mm]		12.5	12.5	12.5	12.5	12.5	12.5	12.5	12.5	12.5	2.5	2.5	2.5	
Body dimensions [mm]	W	173	173	173	173	173	95	95	95	95	173	173	173	
	L	267	267	267	317	317	215	215	265	265	267	267	317	
	H	191	191	191	191	191	191	191	191	191	195	195	195	
Weight [kg]		6.25	6.25	6.25	6.75	6.75	2.45	2.45	3.00	3.00	6.75	6.75	7.25	
Facilities required		115/230VAC, 50/60Hz, 40VA, Vacuum 12"Hg									115/230VAC, 50/60Hz, 40VA			
Flat / Notch Compatibility		According to SEMI standards range												
Cleanliness		Class 1												
MTBF		More than 70000 hours												

LOGOSOL PREALIGNERS ORDERING GUIDE

Doc. # 742000005

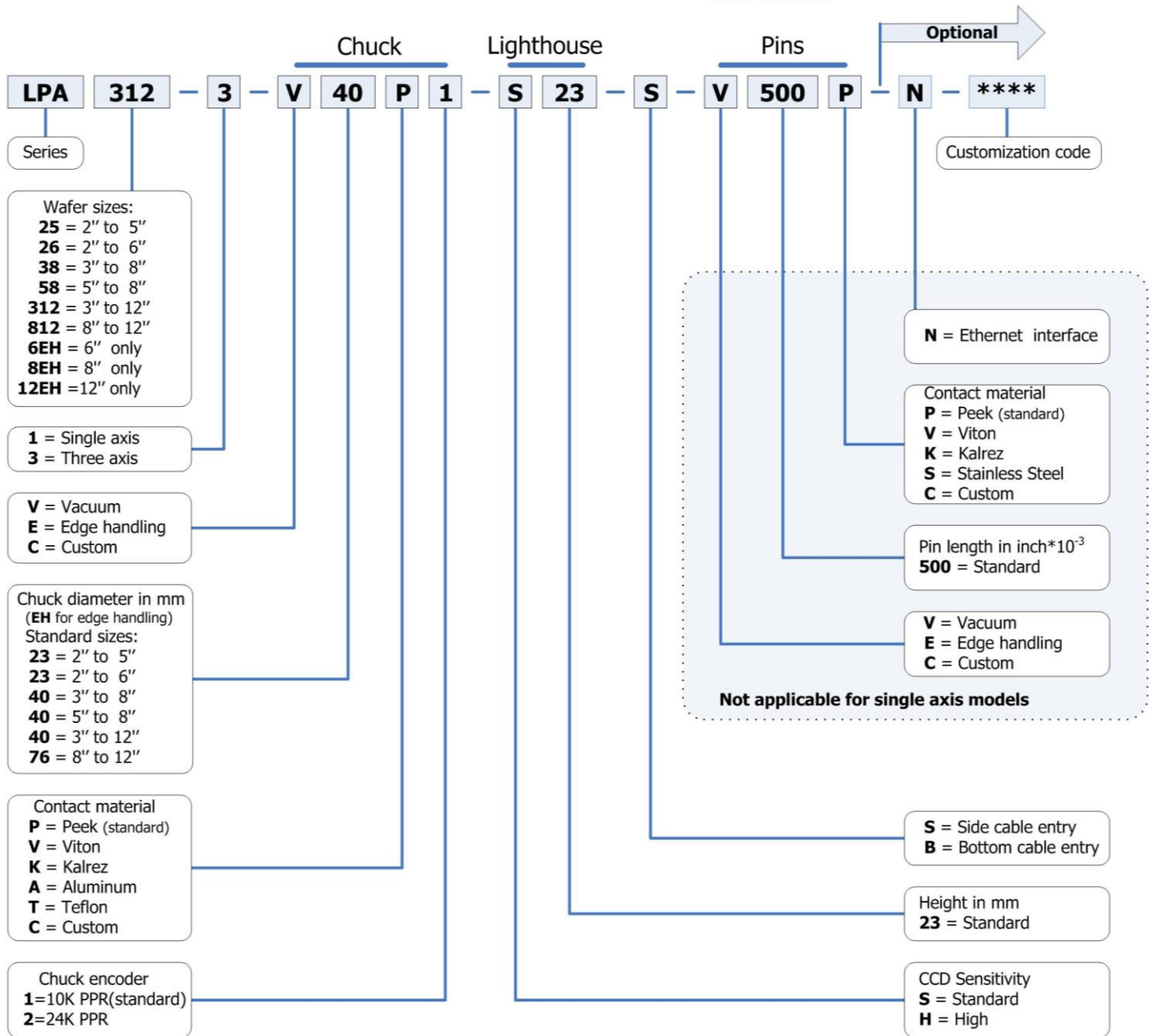

**THREE AXIS STAND ALONE PREALIGNER
LPA312-3-V40-P-1-S23-S-V500S**

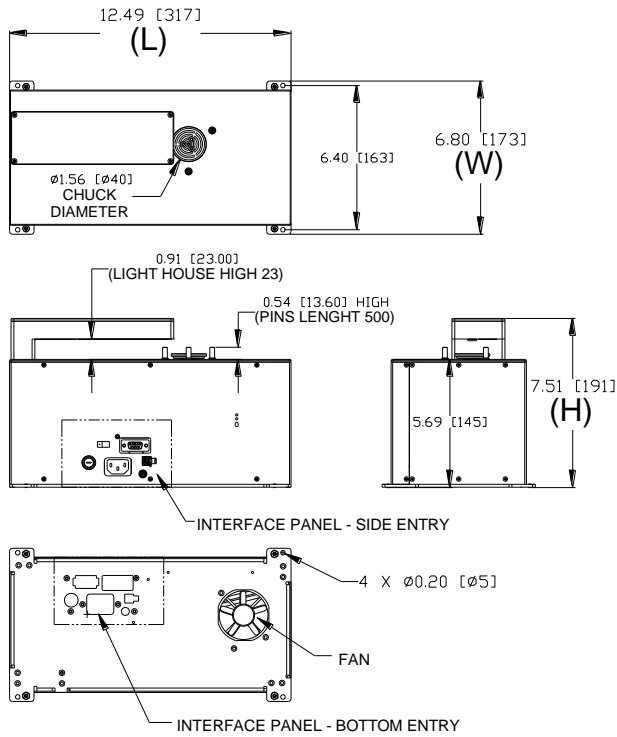

**SINGLE AXIS PREALIGNER
LPA312-1-V40-P-1-S23-S**

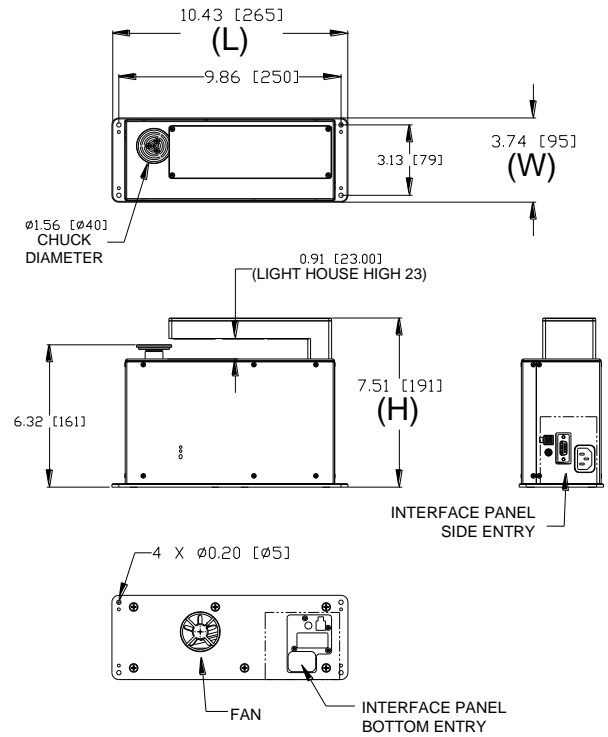

**THREE AXIS STAND ALONE PREALIGNER
LPA38-3-V40-P-1-S23-S-V500S**

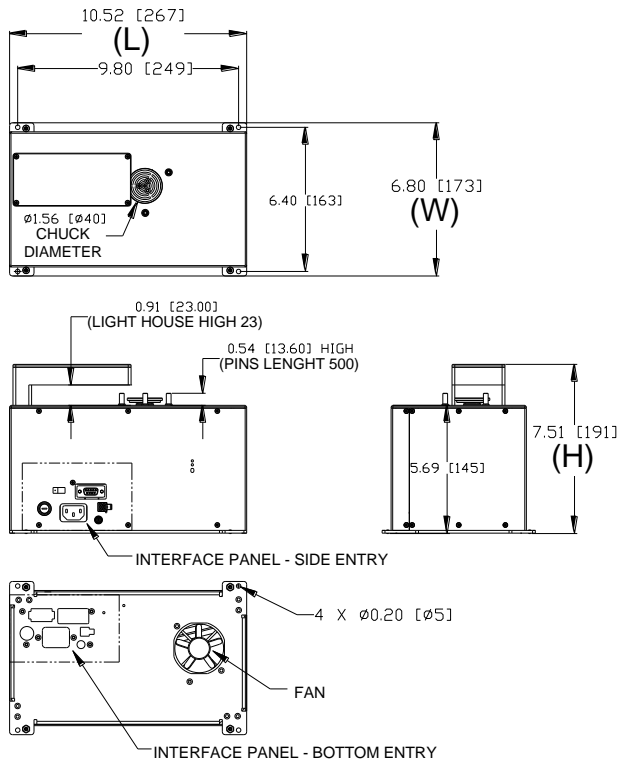

**SINGLE AXIS PREALIGNER
LPA58-1-V40-P-1-S23-S**

